

Metal Garden Shed

OWNER'S MANUAL / Instructions for Size 10' x 8'

Ver: 1.2

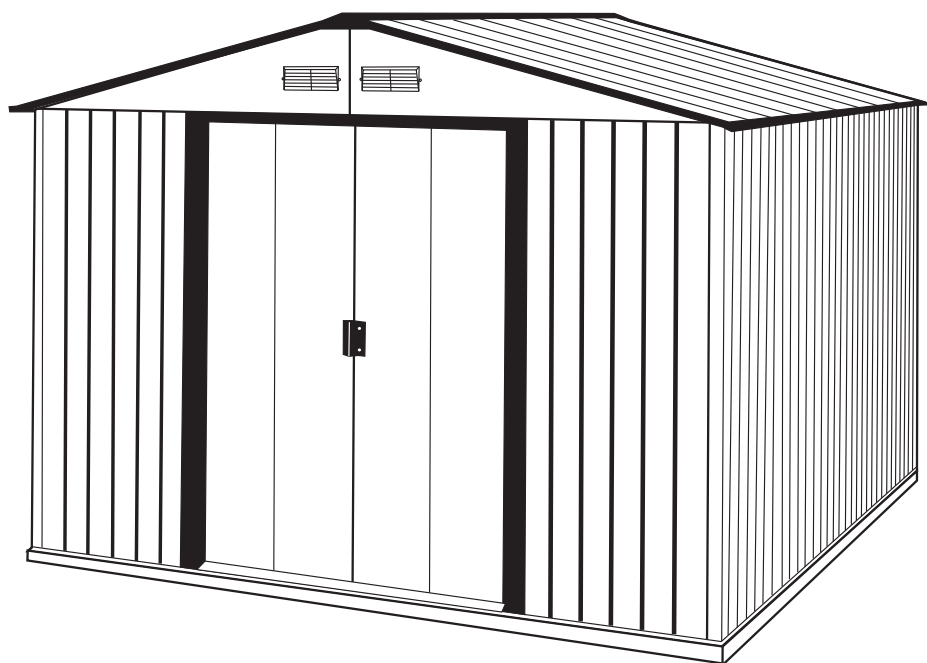

**Customer
Service
Hotline**
www.uspolymersinc.co

Requires two people and takes 2-3 hours for

- Tall Walk in Shed
- Quick & Easy Assembly
- Ridge Reinforced Walls
- Wide Double Doors
- Available in Various Sizes

Call us for any missing or damaged parts.
Do not return to the store.

Parts List

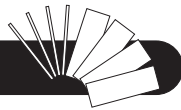

Note: Check all parts prior to installation.

ACCESSORIES

CODE	DESCRIPTION	QTY
BLA	BASE BAR BACK LEFT	1
BRA	BASE BAR BACK RIGHT	1
BS1A	BASE BAR SIDE FRONT LEFT / BACK RIGHT	2
BS2A	BASE BAR SIDE FRONT RIGHT / BACK LEFT	2
BBF	BASE BAR FRONT	2
ECA	ENTRANCE TAPER CHANNEL	1
DCL	DOOR COLUMN PROFILE LEFT	1
DCR	DOOR COLUMN PROFILE RIGHT	1
ABLA	TOP ANGLE BACK LEFT	1
ABRA	TOP ANGLE BACK RIGHT	1
AS1A	TOP ANGLE SIDE FRONT LEFT / BACK RIGHT	2
AS2A	TOP ANGLE SIDE FRONT RIGHT / BACK LEFT	2
SCA	SLIDING CHANNEL COVER LEFT / RIGHT	2
SSA	SLIDING CHANNEL SUPPORT	1
SLA	SLIDING CHANNEL LEFT	1
SRA	SLIDING CHANNEL RIGHT	1
RS1A	ROOF SUPPORT FRONT / BACK	4
RS2A	ROOF SUPPORT FRONT / BACK	4
SB1A	ROOF SUPPORT BRACKET FRONT RIGHT / BACK LEFT	2
SB2A	ROOF SUPPORT BRACKET FRONT LEFT / BACK RIGHT	2
RF1A	ROOF FLASHING FRONT RIGHT / BACK LEFT	2
RF2A	ROOF FLASHING FRONT LEFT / BACK RIGHT	2
RFSA	ROOF FLASHING SIDE FRONT / BACK	4
RFCA	ROOF FLASHING CENTER	2
TSLA	DOOR PANEL STRIP TOP LEFT	1
TSRA	DOOR PANEL STRIP TOP RIGHT	1
BSLA	DOOR PANEL STRIP BOTTOM LEFT	1
BSRA	DOOR PANEL STRIP BOTTOM RIGHT	1
DSS	DOOR PANEL STRIP SIDE LEFT / RIGHT	2
WCF	WALL PANEL CORNER FRONT LEFT / RIGHT	2
WCB	WALL PANEL CORNER BACK LEFT / RIGHT	2
WS	WALL PANEL SIDE	9
WFL	WALL PANEL FRONT LEFT	1
WFR	WALL PANEL FRONT RIGHT	1
GPLA	GABLE PANEL LEFT	2
GPRA	GABLE PANEL RIGHT	2
GPS	GABLE PANEL SUPPORT	2
RP1A	ROOF PANEL FRONT LEFT / BACK RIGHT	2
RP2A	ROOF PANEL CENTER FRONT LEFT & BACK RIGHT	2
RP3A	ROOF PANEL CENTER FRONT RIGHT & BACK LEFT	2
RP4A	ROOF PANEL FRONT RIGHT & BACK LEFT	2
DPL1A	DOOR PANEL LEFT	1
DPL2A	DOOR PANEL LEFT	1
DPR1A	DOOR PANEL RIGHT	1
DPR2A	DOOR PANEL RIGHT	1

CODE	DESCRIPTION	QTY
BS	BOTTOM SLIDER	4
DH	DOOR HANDLE	2
FC	FLASHING END CAP	2
TC	TOP CORNER	4
TS	TOP SLIDER	4
VC	VENTILATION COVER	4
PW	PLASTIC WASHER	240
PC	PLASTIC SCREW COVER	124
WST	WEATHER STRIPPING TAPE	3.1MTR
S1	DIA. 4.2 x 10mm. (5/32" x 3/8")	
	SHEET METAL SCREW	282

PROFILES

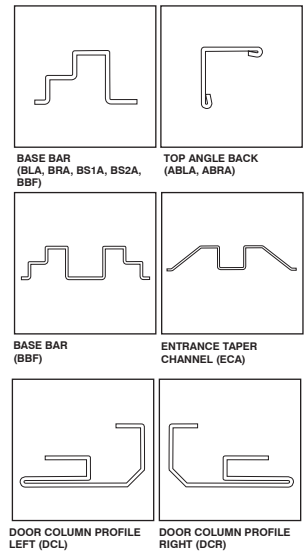

ACCESSORIES

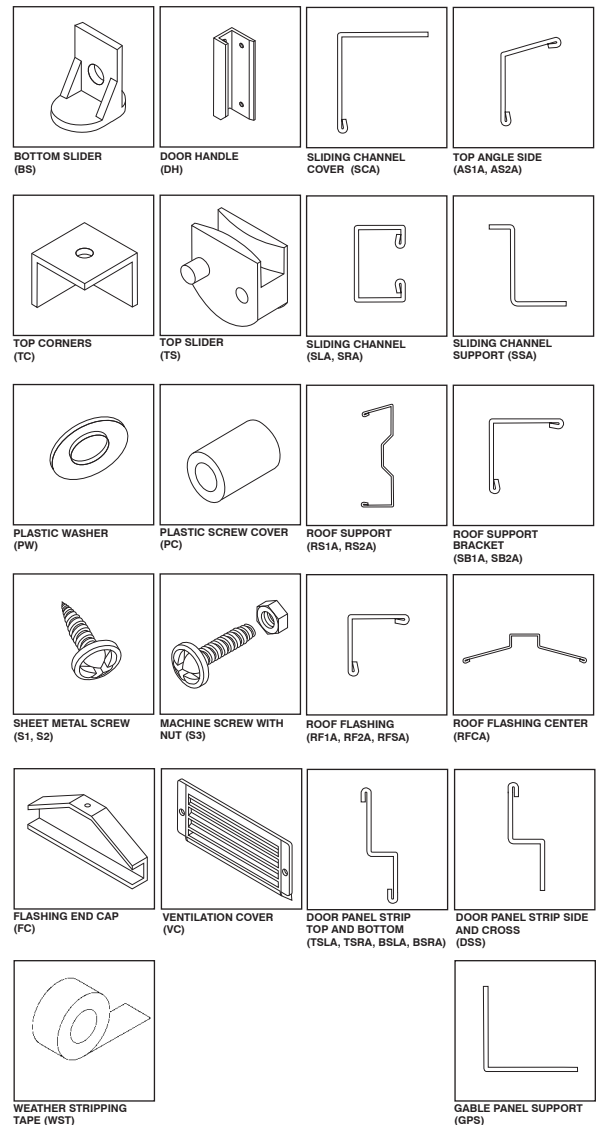

Tools You Will

- | | |
|-------------------------------|-------------------|
| Hand Gloves | 8' Step Ladder |
| Cordless Drill - Philips Head | Adjustable pliers |
| Screw driver - Philips Head | Level - 3ft. |
| Carpenter's Square | Tape Measure |
| Eye Protector | |

IMPORTANT: USE HAND GLOVES TO PREVENT INJURY.

Exploded View

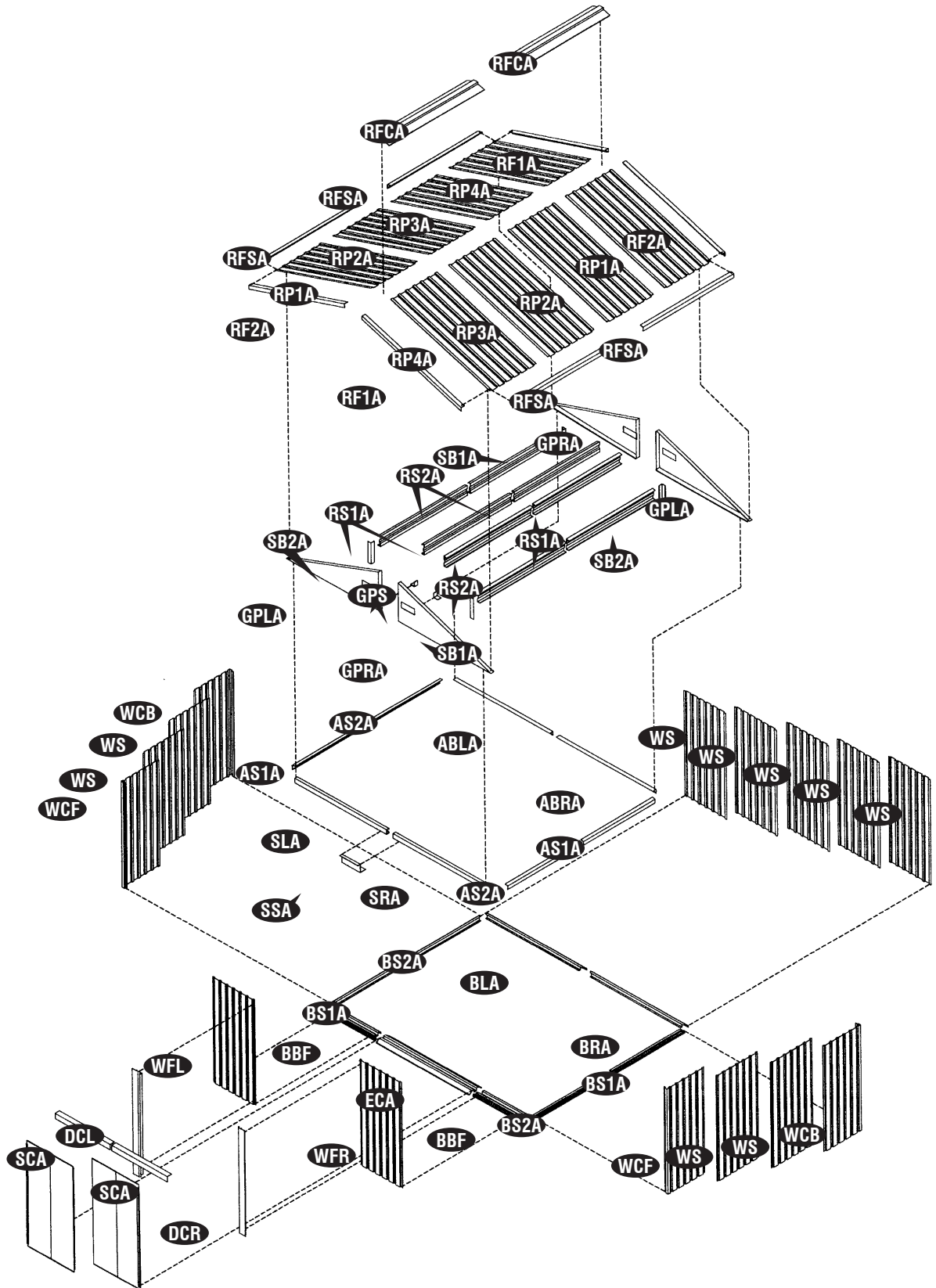
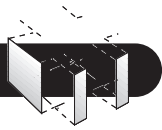

Left Door

Right Door

IMPORTANT: USE HAND GLOVES TO PREVENT INJURY.

Duramax Storage Shed Limited Fifteen Year Warranty

U.S. Polymer Inc. will send a replacement part free of charge, in the event of material defects and or workmanship for a period of fifteen years from the date of purchase.

This warranty is extended only to the original purchaser. A purchase receipt or other proof of date of original purchase will be required before warranty service is rendered. In no event shall we pay the cost of flooring, labor, installation or any other costs related thereto.

This warranty only covers failures due to defects in material or workmanship which occurs during normal use and does not extend to color change arising due to normal weathering or to damage resulting from misuse or neglect, commercial use, failure to follow assembly instructions and the owner's manual (including proper anchoring of the shed), painting, forces of nature and other causes which is beyond our control.

Claims under this warranty must be made within the warranty period by calling 1-800-483-4674 or mail in a dated sales slip and clear photograph of the part to:

U.S. Polymers, Inc.
6915 Slauson Avenue
Commerce, CA 90040

We reserve the right to discontinue or change components. If a component has been discontinued or is not available, U.S. Polymers, Inc. reserves the right to substitute a component of equal quality as may be compatible.

Limits and Exclusions

There are no express warranties except as listed above. The warrantor shall not be liable for incidental or consequential damages resulting from the use of this product, or arising out of any breach of this warranty. All express warranties are limited to the warranty period set forth above. Some states do not allow the exclusion or limitation on how long an implied warranty lasts, so the above limitations may not apply to you.

This warranty gives you specific legal rights and you may also have other rights which vary from state to state or country to country.

A. Foundation & Base

Note: It is important that these instructions are followed step by step.

DuraMax must be installed on a level wooden platform or a level concrete foundation.

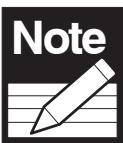

Wooden platform is extra and is not included. Don't install under windy conditions.

Parts needed:

- (1) Base bar back left (BLA)
- (1) Base bar back right (BRA)
- (2) Base bar side (BS1A)
- (2) Base bar side (BS2A)
- (2) Base bar front (BBF)

- (1) Entrance taper channel (ECA)
- (20) Sheet metal screw (S1)

1. Use pressure treated wood studs **2"x 4" (50mm x 88.9mm)** to create a platform frame that has an outside dimension of **94"x 125"** (2387.6mm x 3175mm).

2. Using exterior grade **CDX 3/4" (19mm)** plywood, cut and fit together the sheets to form solid foundation as shown. Foundation must be

Wooden Platform (Not Included)

The following are a list of lumber and sizes you will need.

Pressure Treated - Wood Studs:

- 2ea 2" x 4" x 125" (50mm x 88.9mm x 3175 mm)
- 6ea 2" x 4" x 87" (50mm x 88.9mm x 2209.8 mm)

Exterior Grade (CDX) - 3/4" (19mm) plywood

- 2ea 3/4" x 48" x 94" (19mm x 1219.2mm x 2387.6mm)
- 1ea 3/4" x 29" x 94" (19mm x 736.6mm x 2387.6mm)

L-Brackets: 4ea

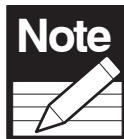

Lay 50 x 88.9mm Flat

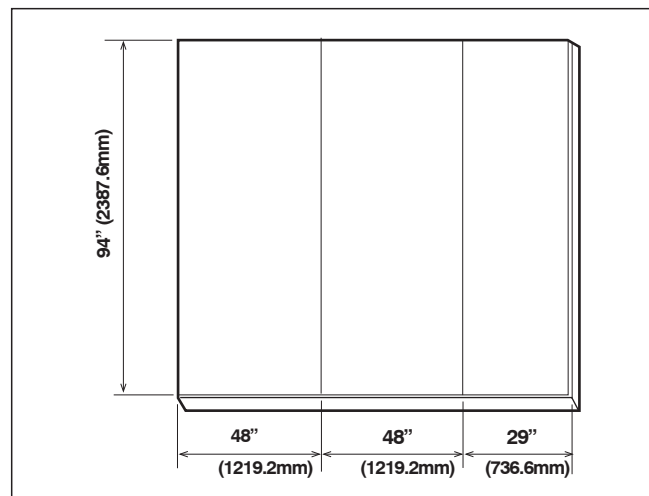
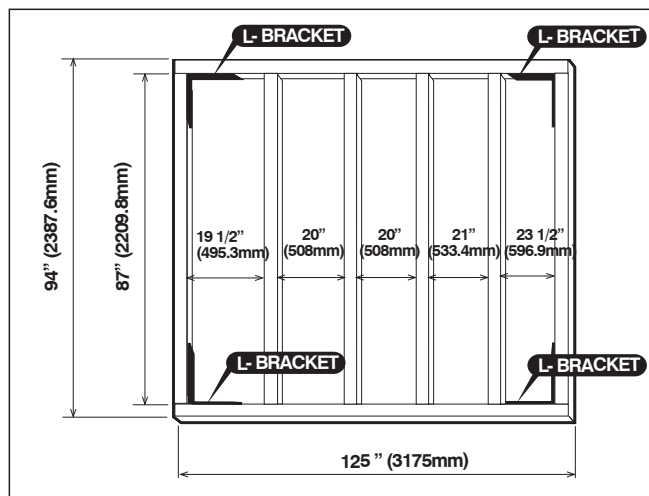
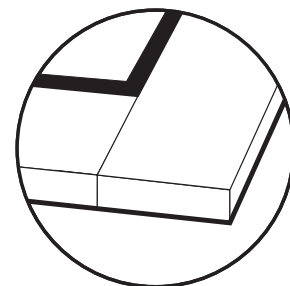

3. Assemble base bar back left (BLA) and base bar back right (BRA) with four (S1) screws.
See fig. 1 & 2.

Note *Take care of sharp edges.*

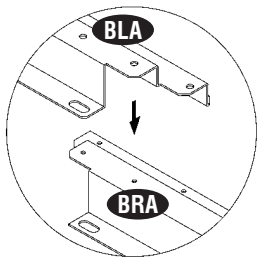

Fig.1

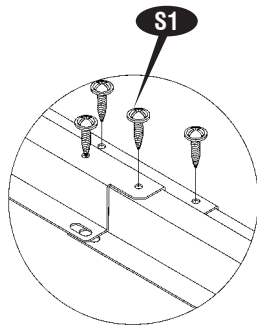
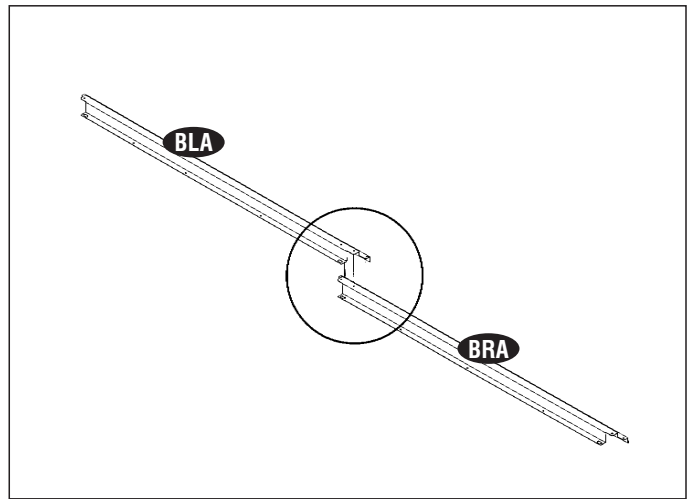

Fig.2



4. Assemble the base bar side (BS1A) and (BS2A)

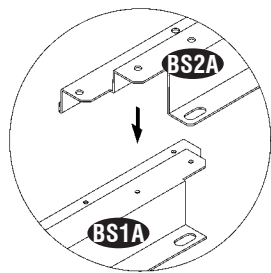

Fig.1

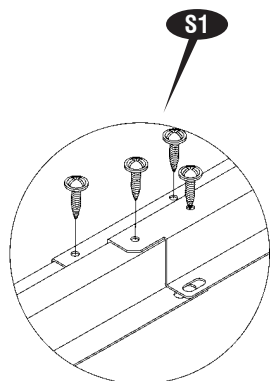
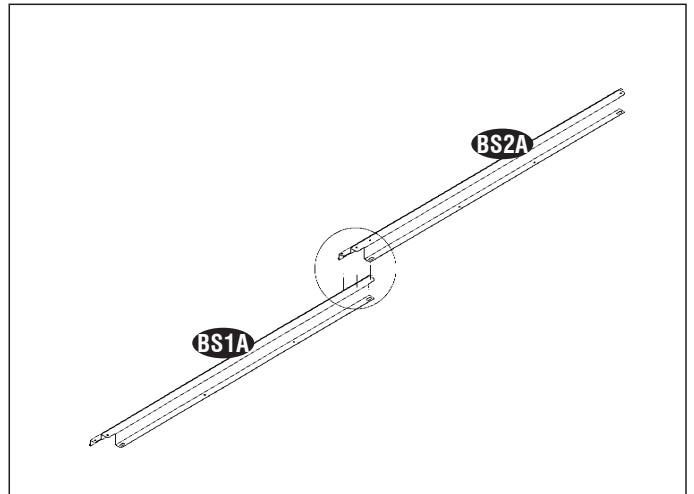
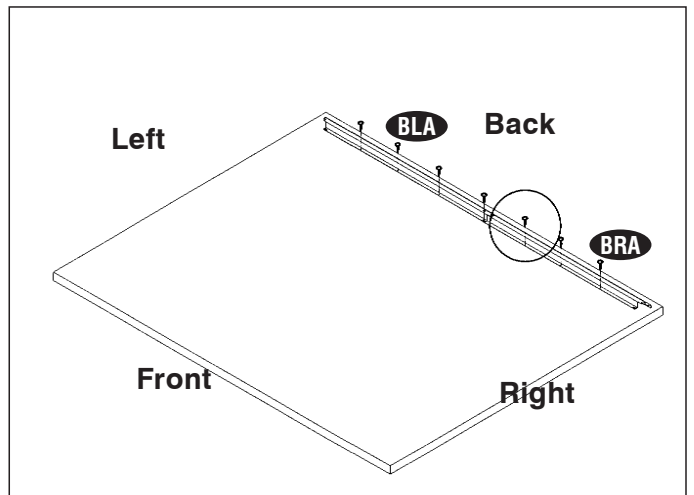
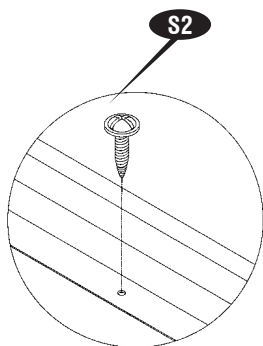

Fig.2



5. Place the base bar assembly on top of the foundation. Use (S2) screws to fix the assembly to foundation.



6. Place the base bar side assembly on left side. Insert the edge of **(BS2A)** into the back base bar **(BLA)** and secure with **(S1)** screws. See fig. 1 Place the base bar side assembly on right side. Insert the edge of **(BS1A)** into the back base bar **(BRA)** and secure with **(S1)** screws. See fig. 2

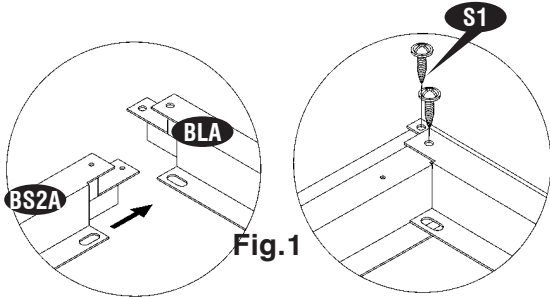

Fig.1

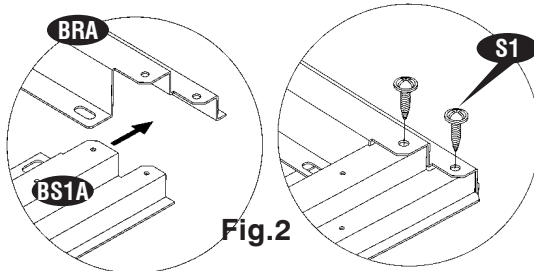
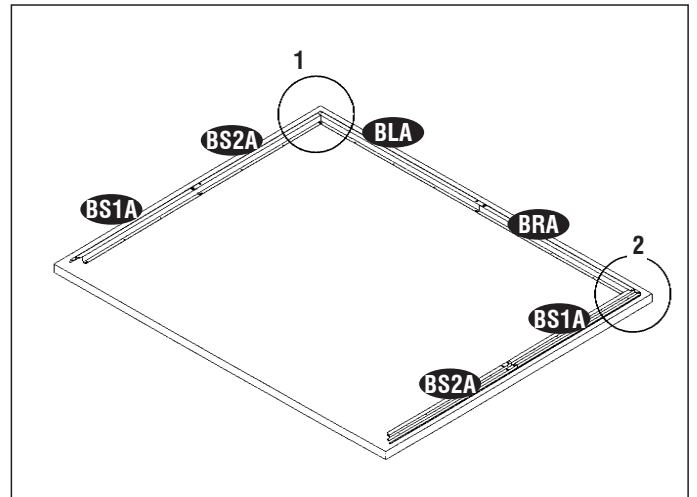

Fig.2



7. Using a carpenter square, line up the corners. Secure base bar side assembly to the foundation with **(S2)** screws.

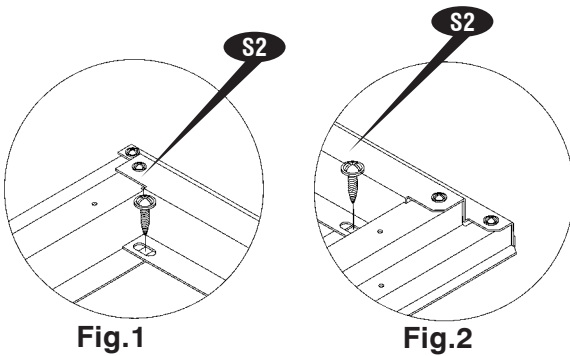
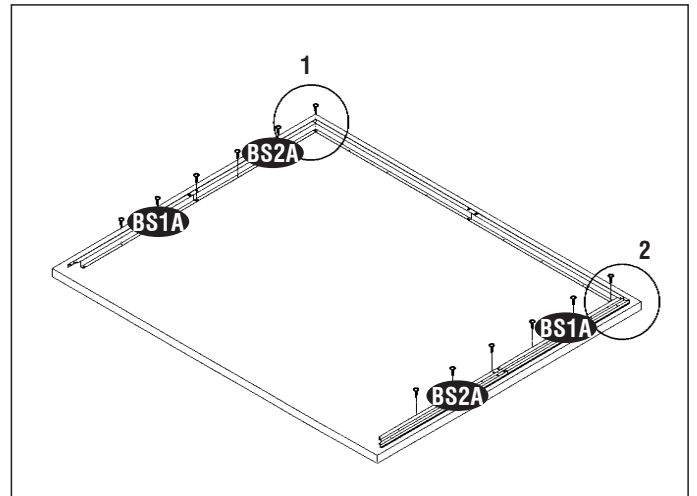

Fig.1

Fig.2



8. Place the base bar **(BBF)** on top of the base bar side on both side. Secure with **(S1)** screws

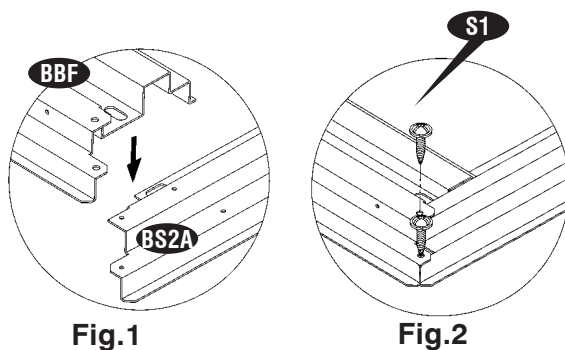
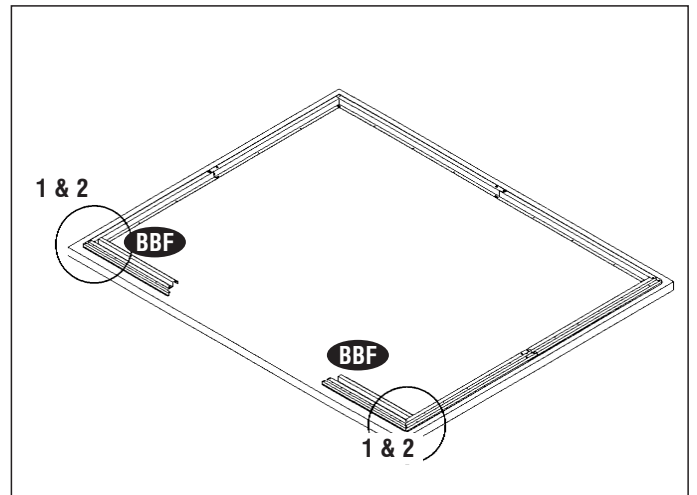
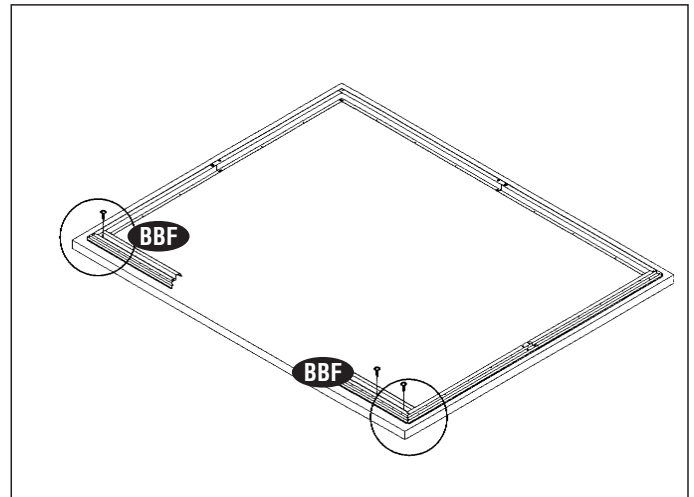
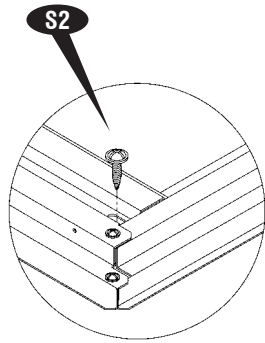

Fig.1

Fig.2



9. Using the carpenter square, line up the corners.



10. Place the entrance taper channel (ECA) on top of the (BBF). Secure with (S2) screws to the foundation. See fig. 1 & 2.

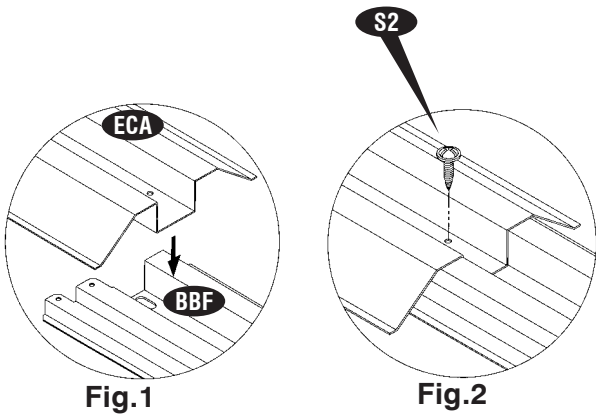
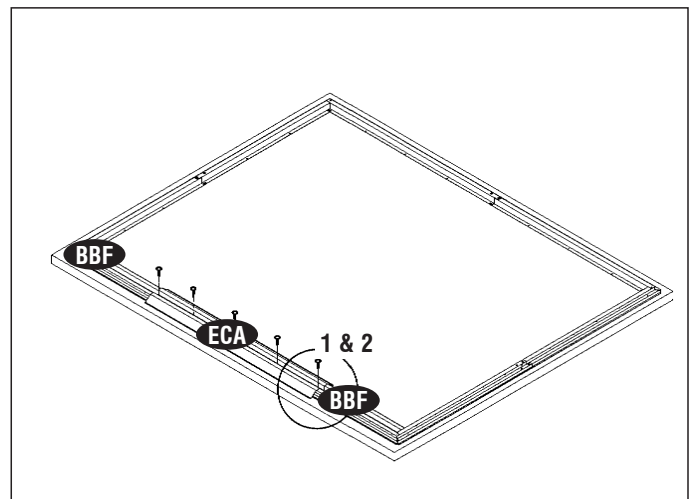
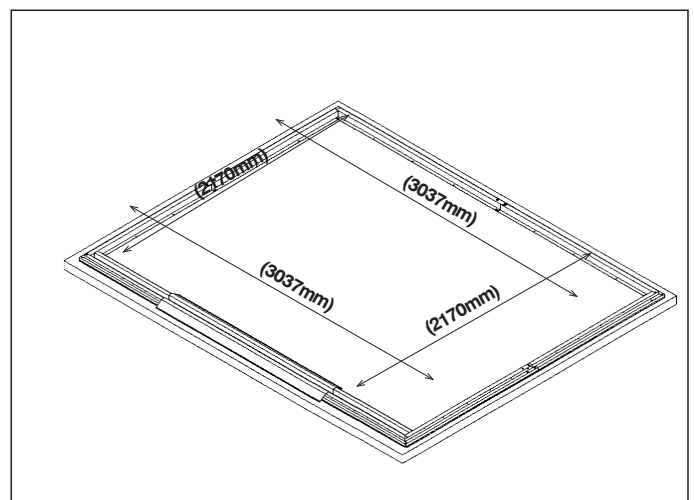

Fig.1

Fig.2



11. Measure in all direction as shown in figure. Make the base bar assembly in a perfect square.



Concrete foundation

11a. (Concrete foundation) Using a carpenter square, line up corners. Align **Base bars**, mark the concrete at the holes in the **base** and drill concrete with 1/4" (dia. 6mm) concrete bit to accept anchor bolts to a 1 3/4" (44mm) depth. Replace **base** and secure with 1/4" x 1 3/8" (M6 x 35mm) anchor bolts (not provided).

B. Walls & Columns



Note



All panels are clearly marked and care should be taken to use the correct one.

Parts Needed:

(1) Wall panel front right □	(WFR)	(2) Top angle side □ □	(AS2A)
(1) Wall panel front left □	(WFL)	(1) Sliding channel support left □	(SSA)
(2) Wall panel corner front □	(WCF)	(2) Sliding channel cover left/right □	(SCA)
(2) Wall panel corner back □	(WCB)	(4) Top slider □ □ □ □	(TS)
(9) Wall panel side □ □	(WS)	(1) Door column profile left □ □	(DCL)
(1) Sliding channel right □	(SRA)	(1) Door column profile right □ □	(DCR)
(1) Sliding channel left □	(SLA)	(120) Sheet metal screw □ □	(S1)
(1) Top angle back left □	(ABLA)	(14) Machine screw □ □	(S3)
(1) Top angle back right □	(ABRA)	(103) Plastic washer □ □	(PW)
(2) Top angle side □ □	(AS1A)		

- Place the wall panel (**WFR**) on the base bar (**BBF**) front right side of the shed. Line up the holes with

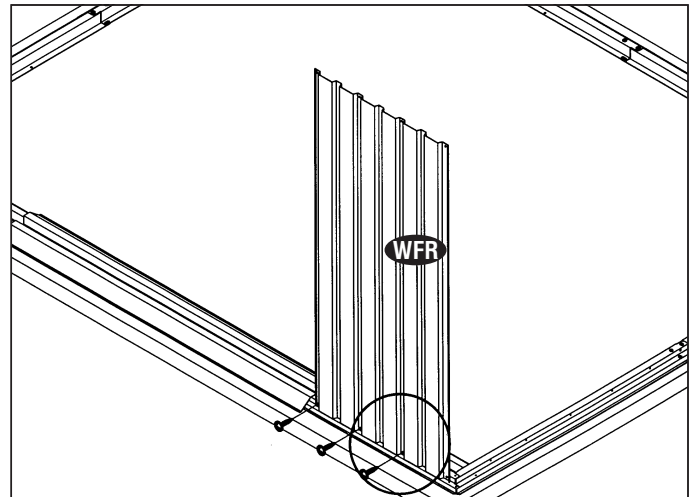
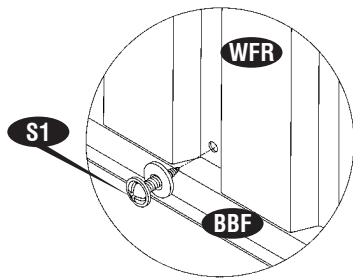

- Place the wall panel corner front (**WCF**) on the base bar (**BS2A**). Line up the holes with base bar and use (**S1**) screws with washers to Secure.

Note



Make sure the overlapping position is as shown in fig.1.

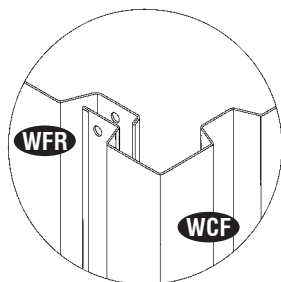

Fig.1

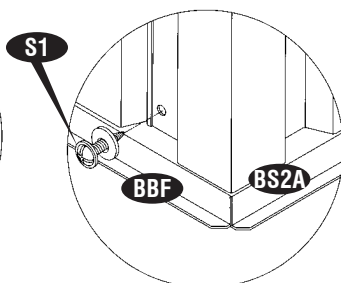
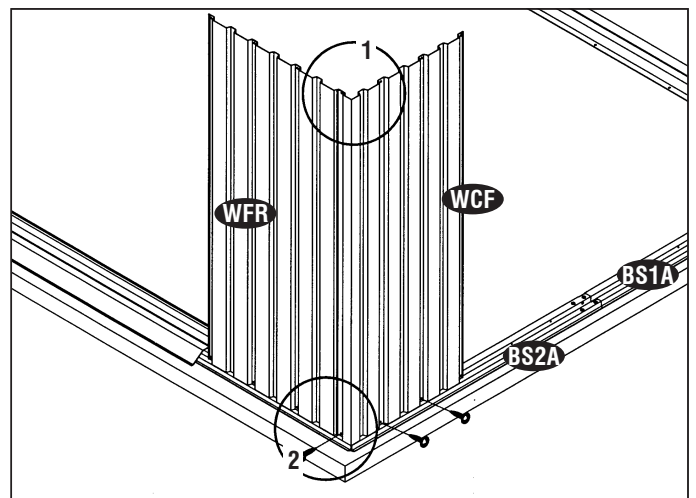
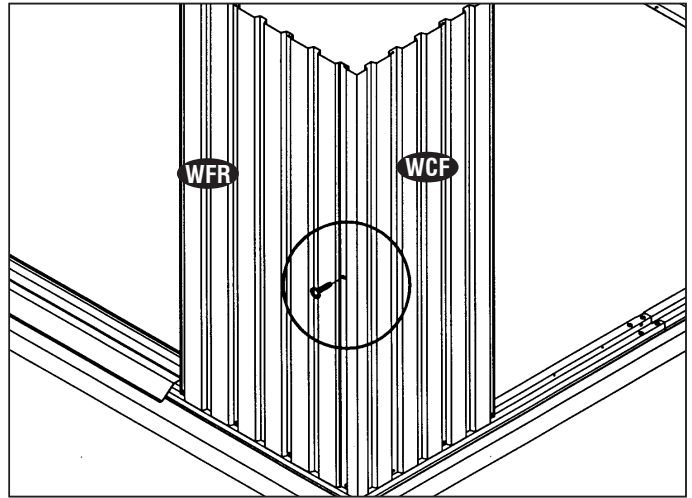
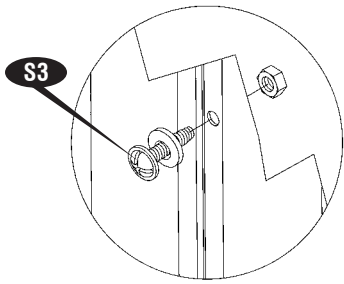

Fig.2



3. Use (S3) bolt and nut with washers to join



4. Place the sliding channel right (SRA) on top of the wall panel (WFR) from inside. See the position in fig.1. Line up the holes with wall panel. Use (S1) screws with washers to fix. See fig. 2 .

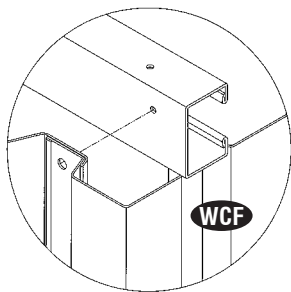

Fig.1

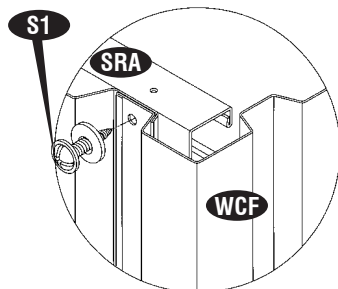
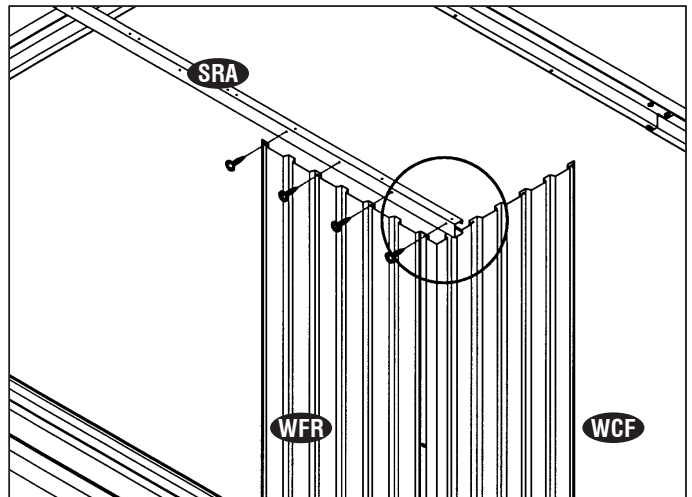

Fig.2



5. Insert two pieces of (TS) Top slider into the

Note



Make sure the position of the projection on (TS) towards inside.

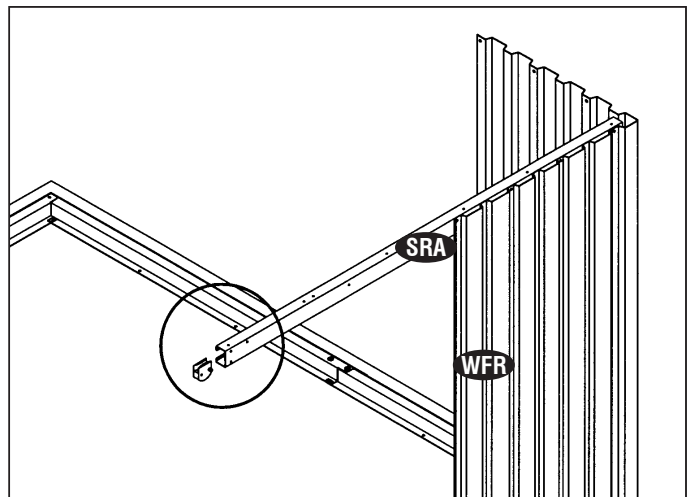
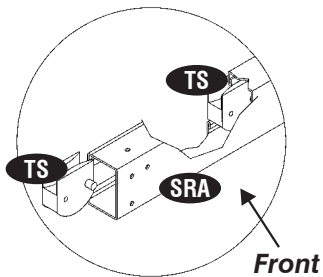

6. Place the wall panel (WFL) on the base bar (BBF) front left side of the shed. Line up the holes with

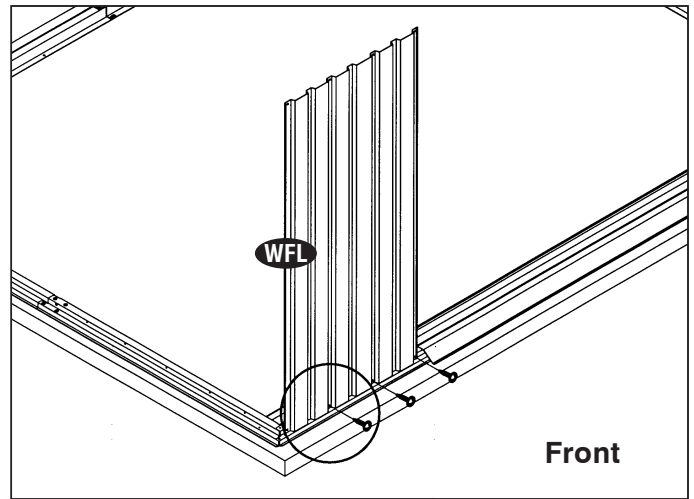
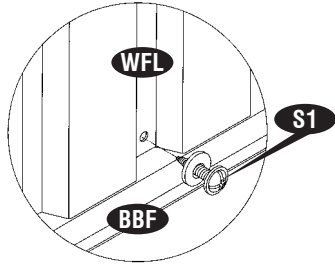

7. Place the wall panel corner front (WCF) on the base bar (BS1A). Line up the holes with base bar and use (S1) screws with washers to secure.

Note *Make sure the overlapping position is as shown in fig.1*

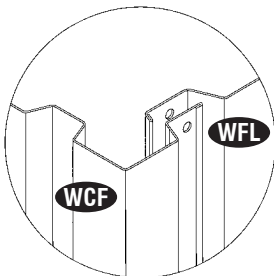

Fig.1

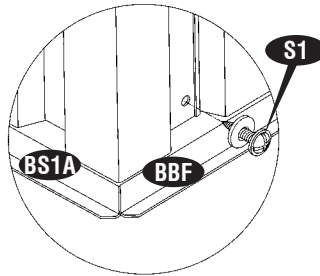
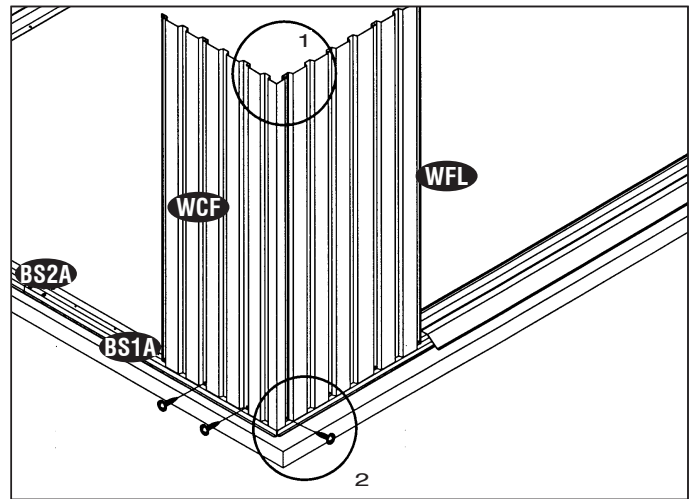
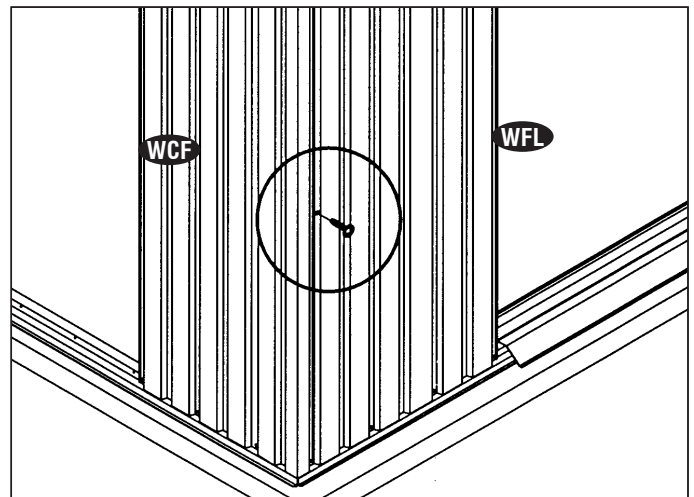
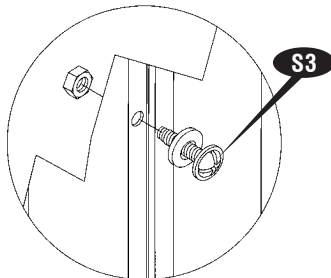

Fig.2



8. Use (S3) bolt and nut with washer to join



9. Place the sliding channel left (SLA) on top of the wall panel (WFL) from inside. See the position in fig1. Line up the holes with wall panel use (S1)

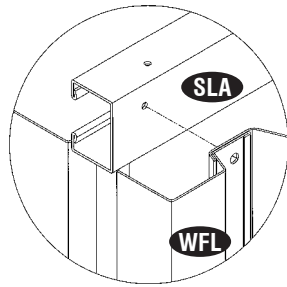

Fig.1

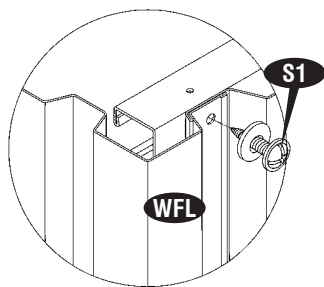
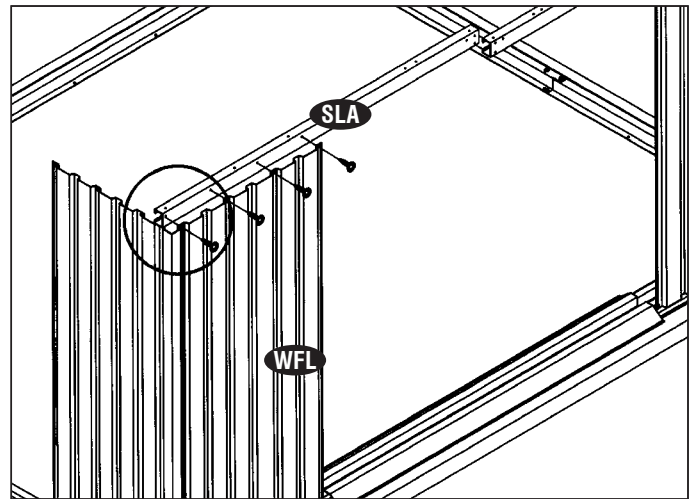
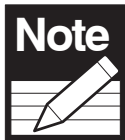

Fig.2



10. Insert two pieces of (TS) Top slider into the sliding channel. See blowup.



Make sure the position of the projection on top slider towards inside.

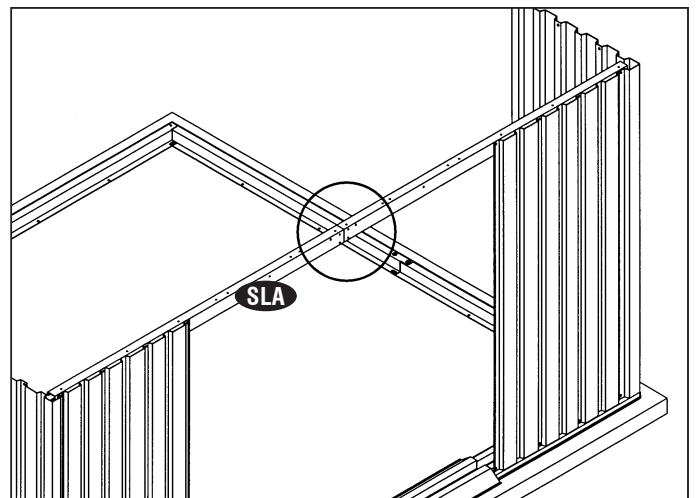
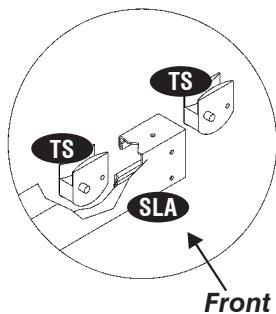

11. Place the sliding channel support (SSA) in between the sliding Channels (SLA) & (SRA). Align the holes with sliding channel and secure with (S1) screws. See fig. 1 & 2.

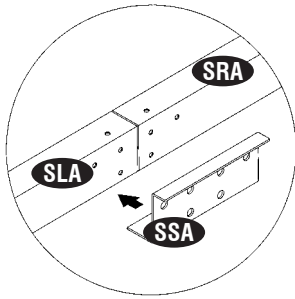

Fig.1

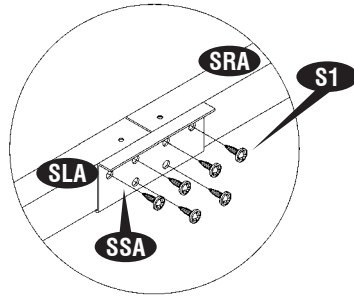
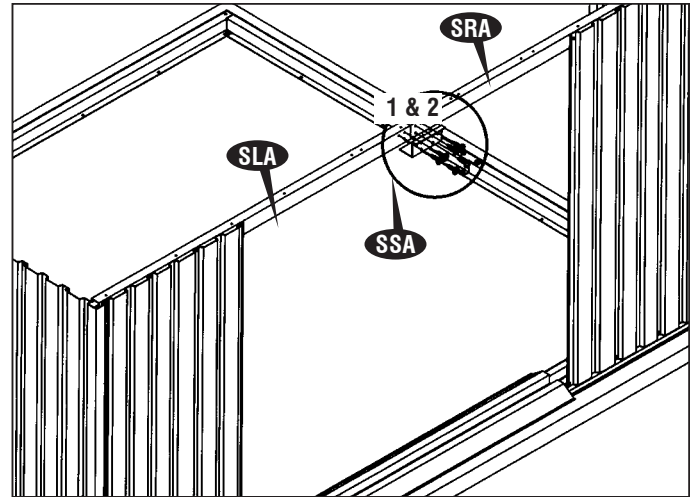
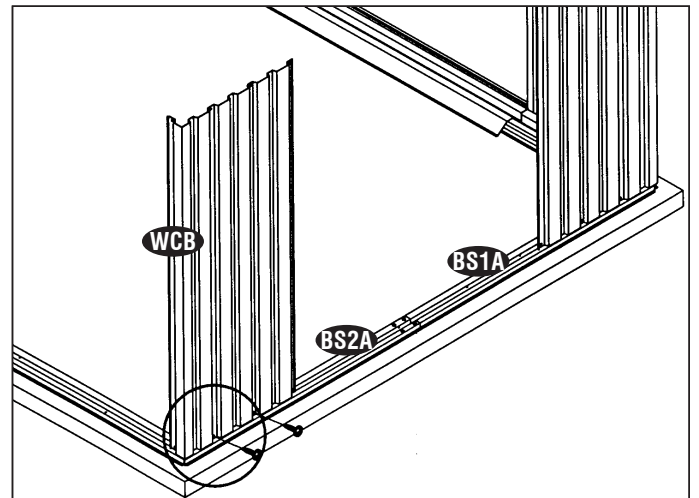
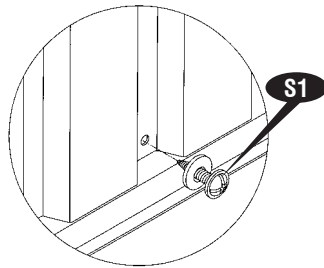

Fig.2



12. Place the wall panel corner back (WCB) on the base bar (BS2A). Line up the holes with base



13. Place the wall panel (WS) on the base bar (BLA). Line up the holes with base bar. Secure with (S1) screws with washers. See fig. 2. Use (S3) bolt and nut with washers to join

Note Make sure the overlapping position is as shown in

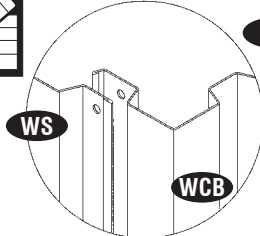

Fig.1

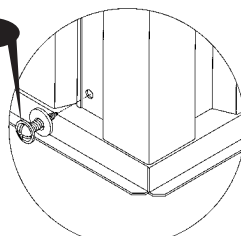

Fig.2

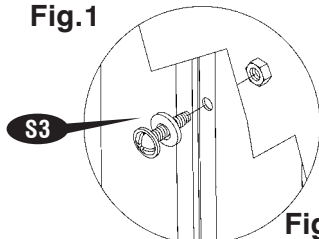
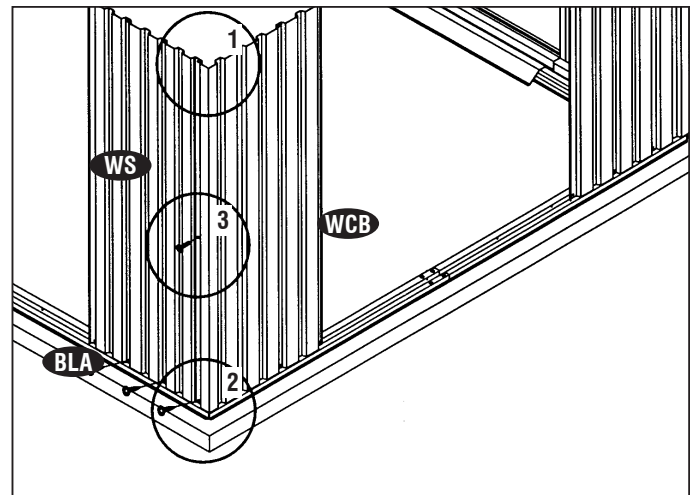
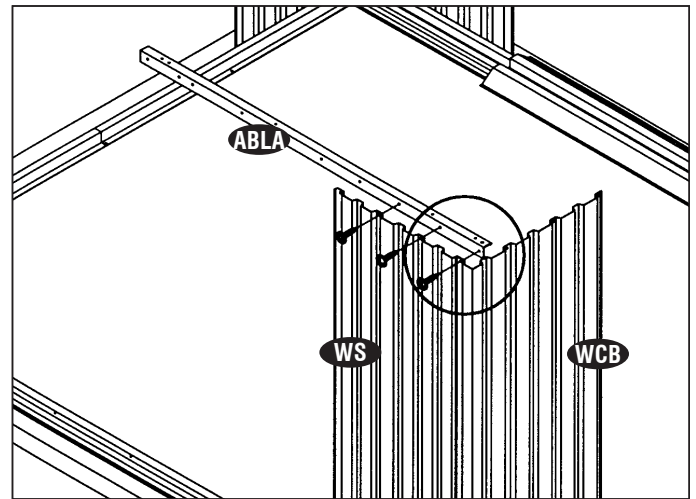
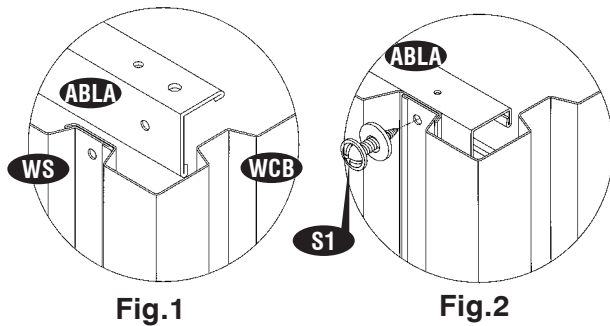

Fig.3



14. Place the top angle back left (**ABLA**) on top of the wall panel (**WS**) from inside. See the position in fig.1. Line up the holes with wall panel. Use (**S1**) screws with washers to fix. See fig. 2.



15. Place the top angle side (**AS2A**) on top of the wall panel (**WCB**). Line up the holes and secure with (**S1**) screws with washers. See fig.1 & 2.

Note *Top angle (AS2A) must sit on top angle (ABLA).*

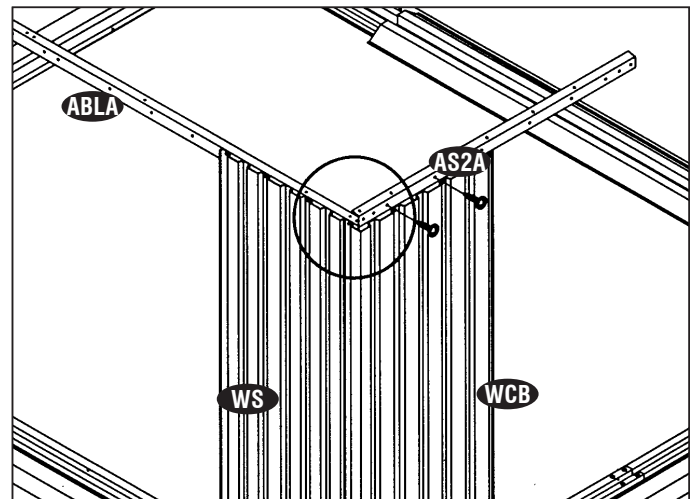
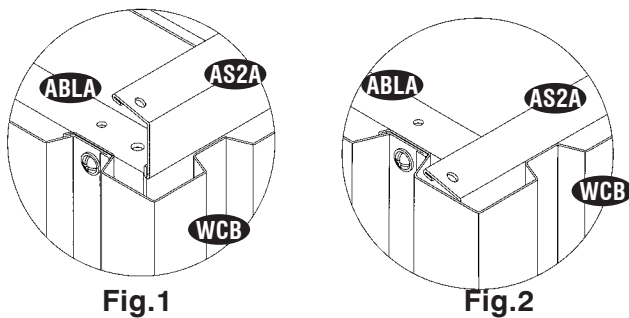

16. Place the top angle side (**AS1A**) on top of the wall panel (**WCF**). Line up the holes and secure with

Note *Top angle (AS1A) must slide in-between the sliding channel (SLA) and*

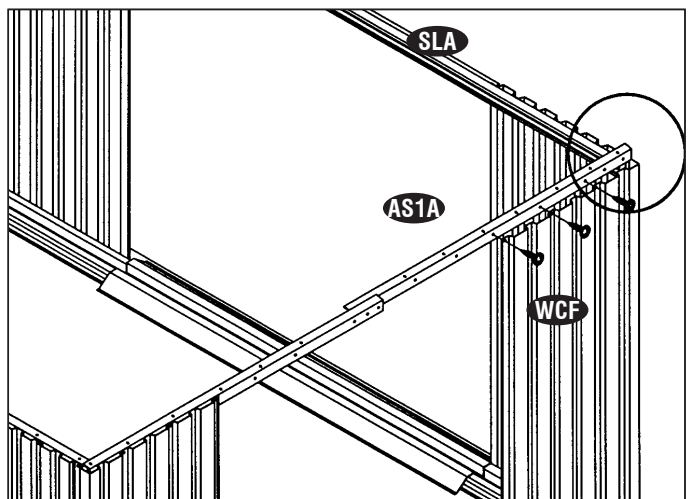
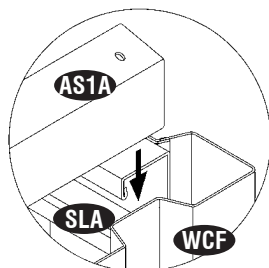

17. Use (S1) screws to join together the top angle from outside (AS1A) and (AS2A).

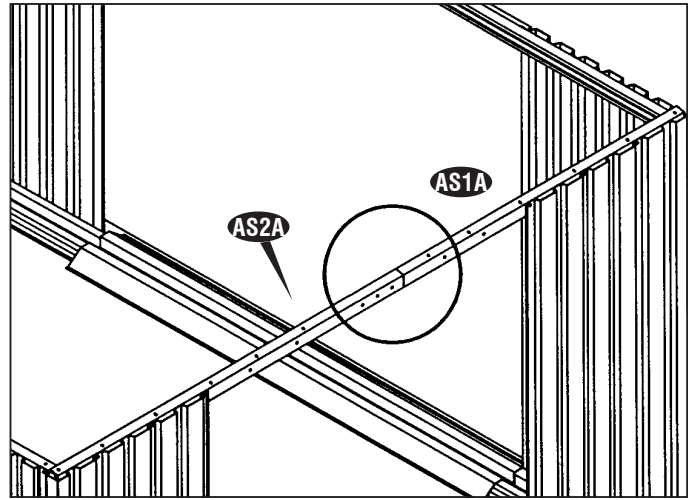
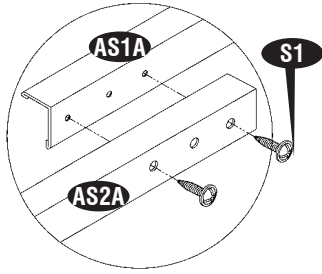

18. Place the wall panel (WS) on top of the base bar and overlap with corner panel (WCF). Secure the wall panel to top angle and base bar with (S1) screws with washers.

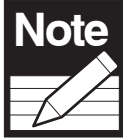

Note Make sure the overlapping position of panels is as shown in fig.

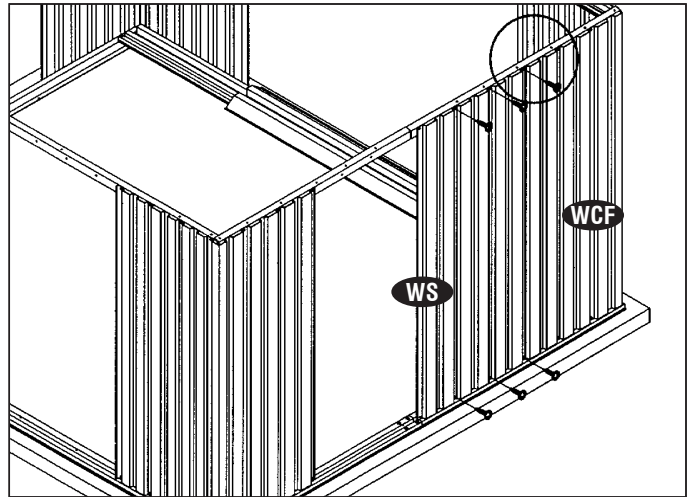
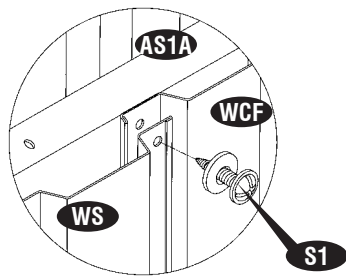

19. Use (S3) bolt & nut with washer to join

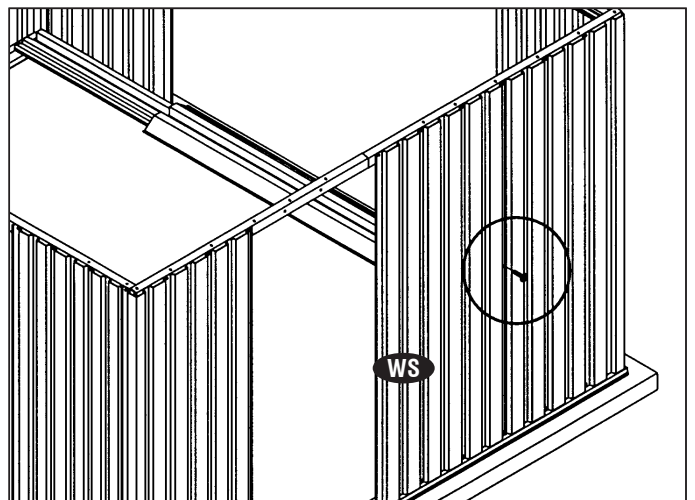
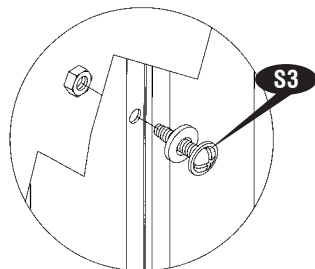

20. Place the wall panel (WS) on the base bar and overlap with corner panel (WCB) and (WS). Secure wall panel to top angle and base bar with (S1) screws with washers.

Note *Make sure the overlapping position of panels is as shown in fig.*

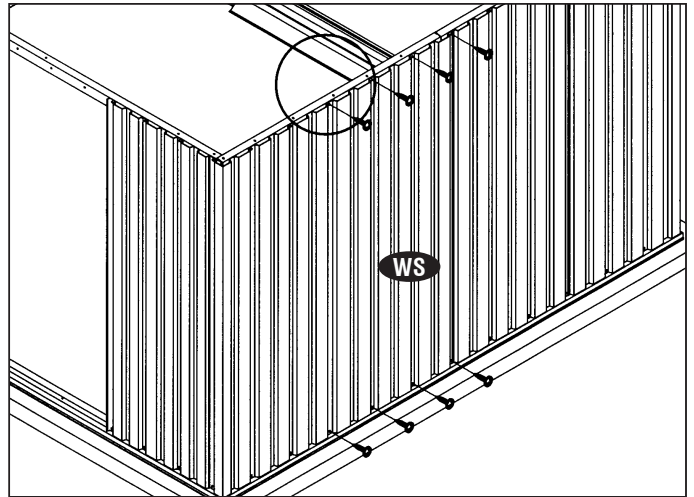
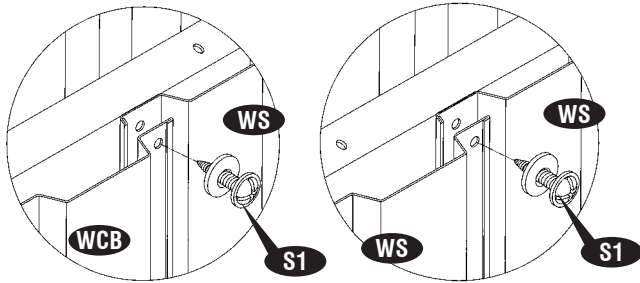

21. Use (S3) bolt & nut with washers to join

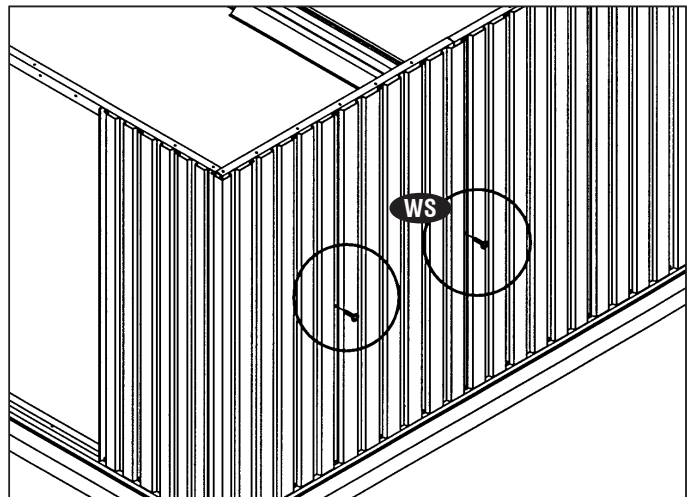
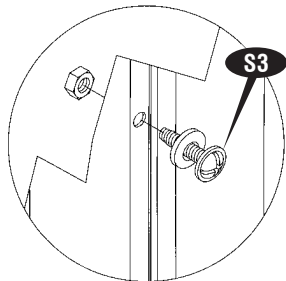

22. Place the wall panel corner back (WCB) on the base bar (BS1A). Line up the holes with base

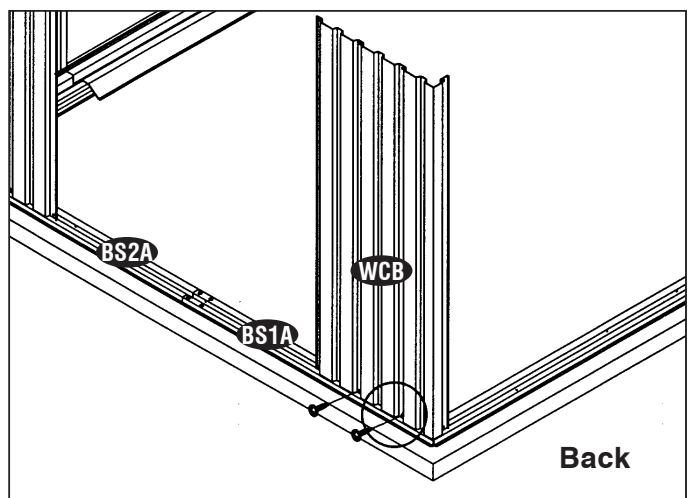
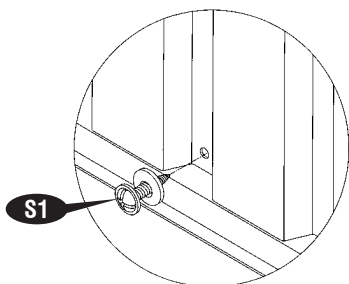

23. Place the wall panel (WS) on the base bar (BRA). Line up the holes with the base bar and use (S1) screws with washers to secure. See fig. 2. Use (S3) nut and bolt with washer to join together

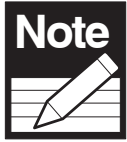

Note Make sure the overlapping of the panels. See fig. 1

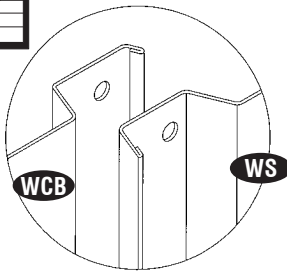

Fig.1

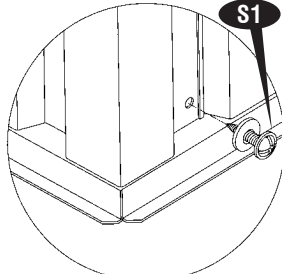

Fig.2

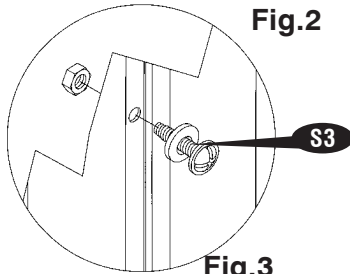
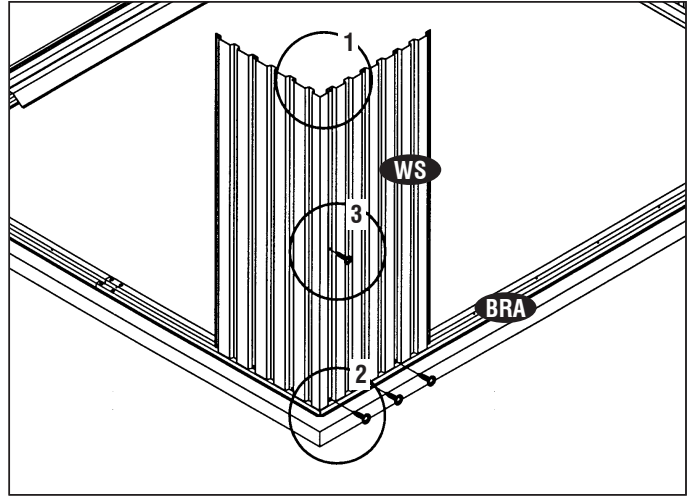

Fig.3



24. Place the top angle back right (ABRA) on top of the wall panel from inside. See the position in fig.1. Line up the holes with wall panel use (S1) screws with washers to secure. See fig 2.

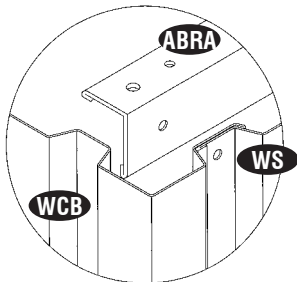

Fig.1

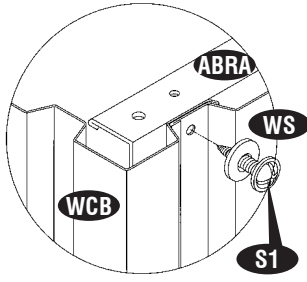
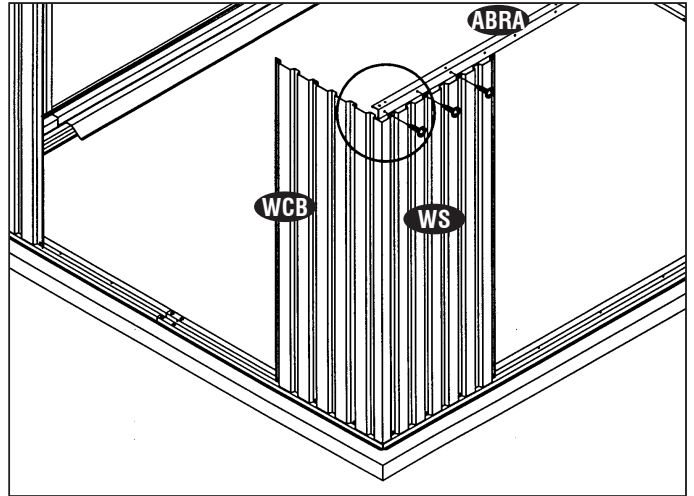
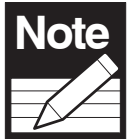

Fig.2



25. Join the top angle back left and right (ABLA) & (ABRA) together with (S1) screws from inside. See blowup.



Note Make sure the overlapping position. See fig.1.

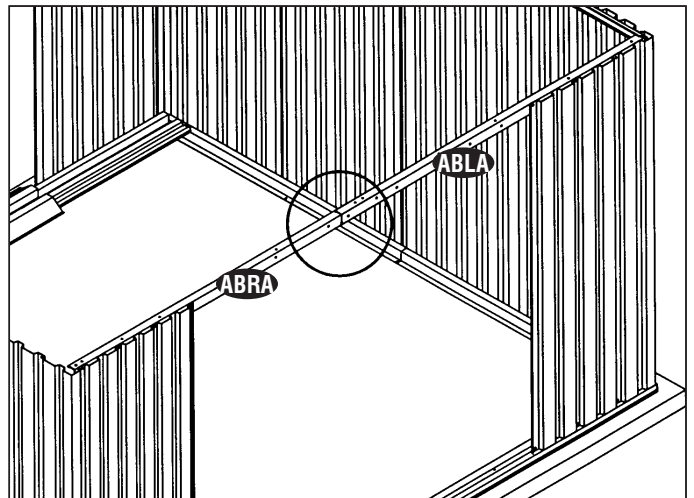
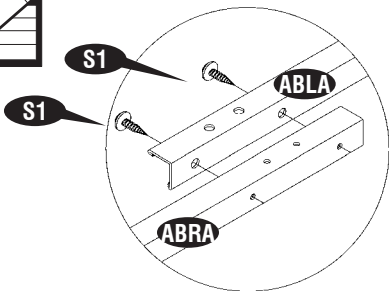

26. Place the top angle side (AS2A) on top of the wall panel (WCF) from inside. Line up the holes with

Note *Top angle (AS2A) must slide in between the sliding channel (SRA) and the wall panel (WCF).*

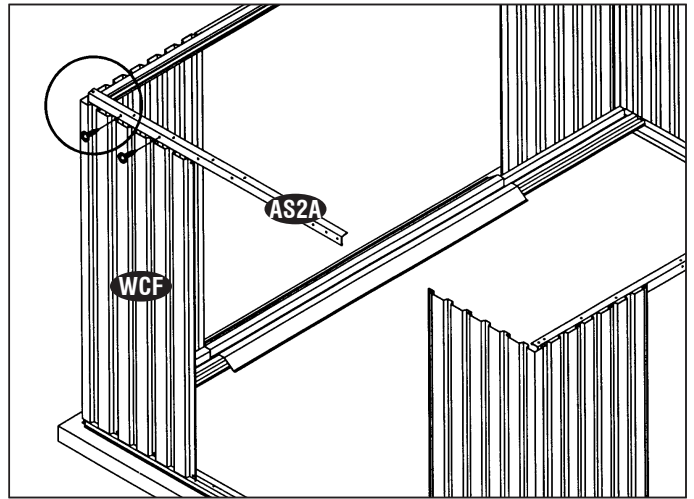
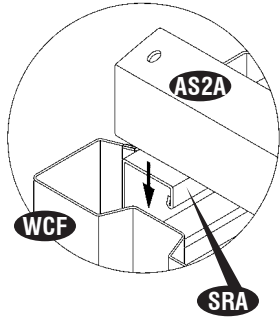

27. Place the top angle side (AS1A) on top of the wall panel (WCB) from inside. Line up the holes with the panel and secure with (S1) screws with washers. See fig. 1 & 2.

Note *Top angle (AS1A) must sit on top angle (ABRA).*

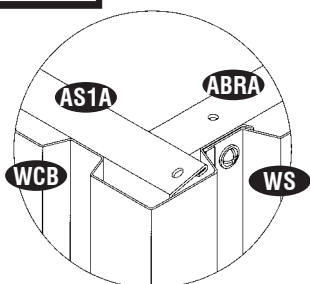

Fig.1

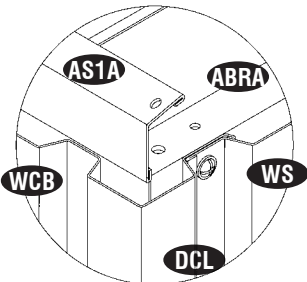
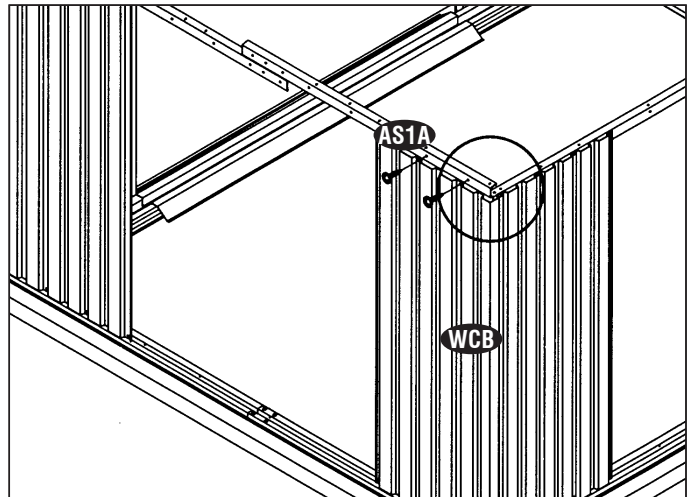
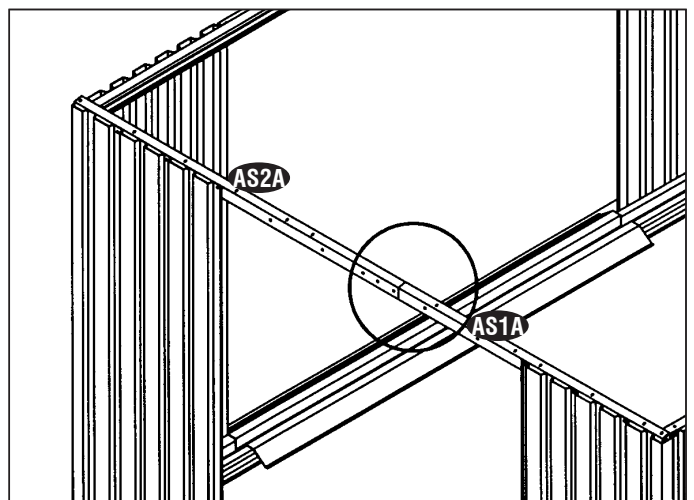
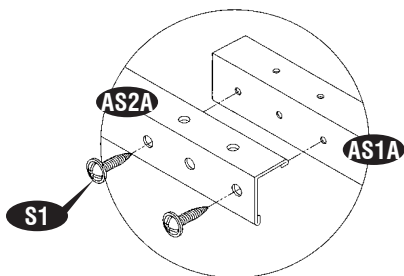

Fig.2



28. Join the top angle side (AS1A) & (AS2A)



29. Place the wall panel (WS) on top of the base bar and overlap with corner panel (WCF). Secure the wall panel to top angle and base bar with (S1) screws with washers. Use (S3) bolt and nut with washer to join together in the middle of the wall panel. See fig. 2

Note *Make sure the overlapping position is as shown in*

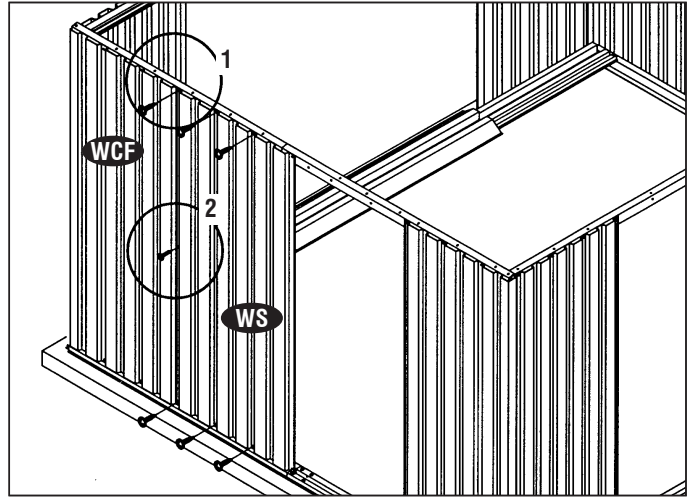
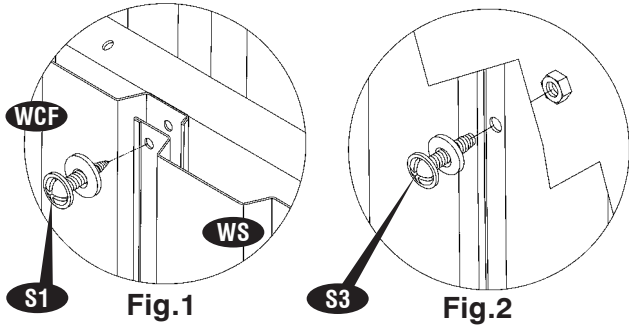

30. Place the wall panel (WS) on top of base bar and overlap with other panel. Secure with (S1) screws with washers. Use (S3) bolt and nut with washers to join together the middle of the wall panels. See fig. 3.

Note *Make sure the overlapping position is as shown in fig. 1 & 2.*

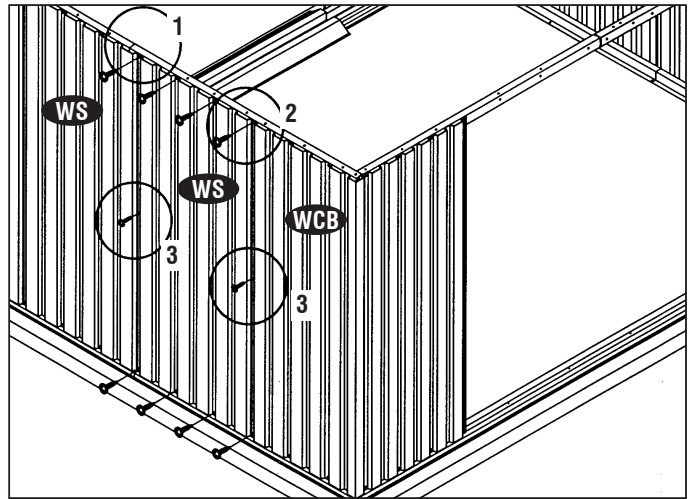
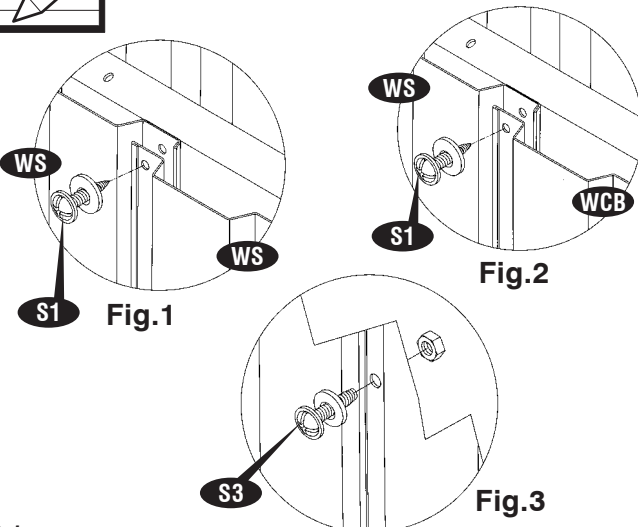

31. Continue to place the wall panel (WS) on top of base bar and overlap the wall panel (WS) and secure with (S1) screws with washers. See fig. 1. Use (S3) bolt and nut with washer to join together the middle of the wall panel. See fig. 2.

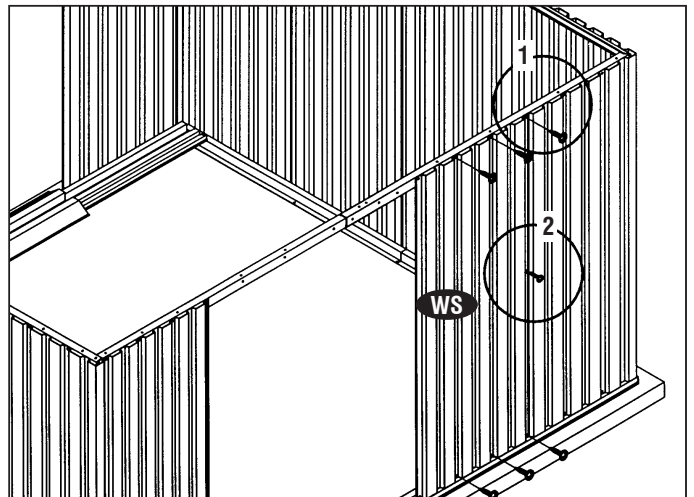
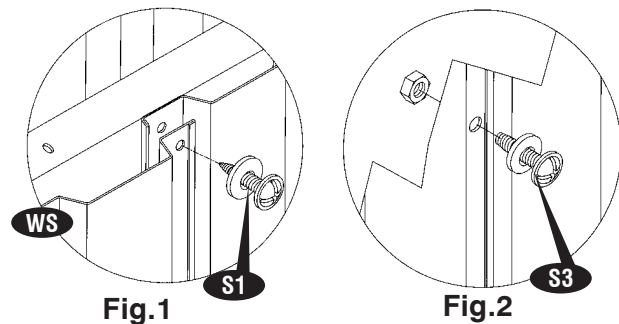

32. Continue to place the wall panel and secure with (S1) screws with washers. See fig. 1.
Use (S3) bolt and nut with washer to join together the middle of the wall panel. See fig. 2.

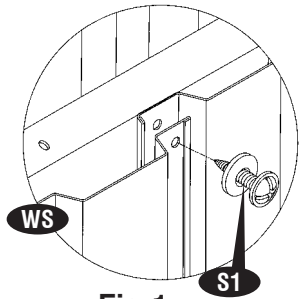

Fig.1

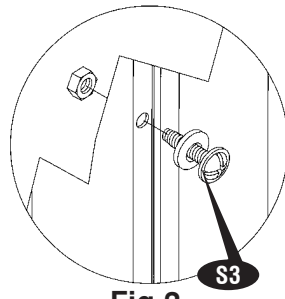
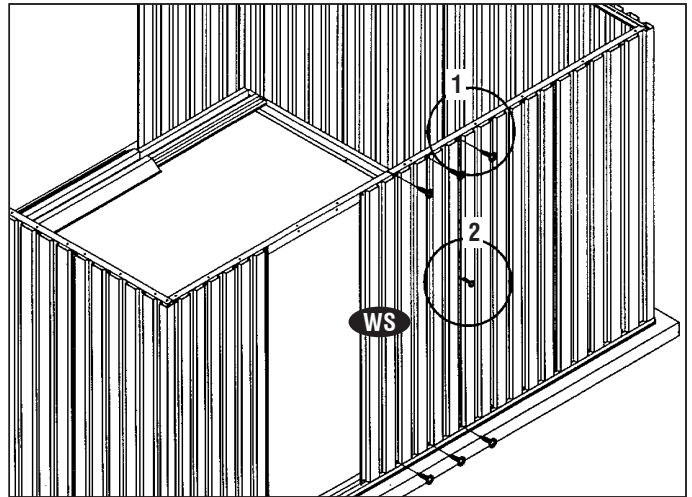
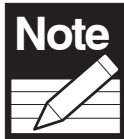

Fig.2



33. Follow the same way as item No. 33.



Note Make sure the overlapping position is as shown in fig.1 & 2.

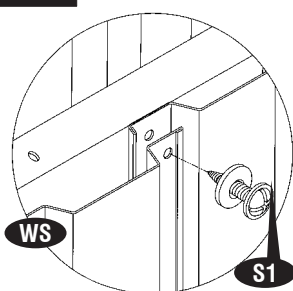

Fig.1

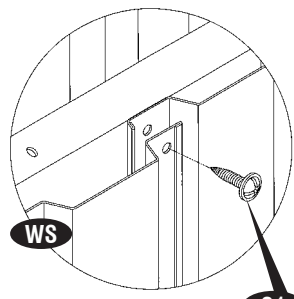

Fig.2

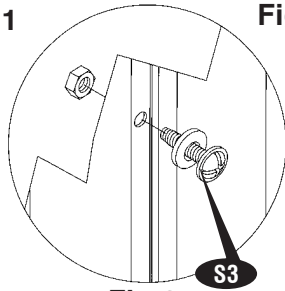
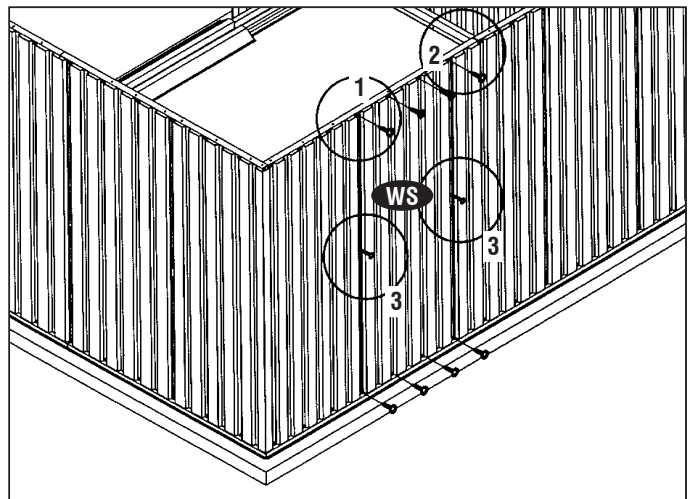

Fig.3



34. Place the left door column (DCL) on top of the base bar (BBF) and insert into the wall panel.

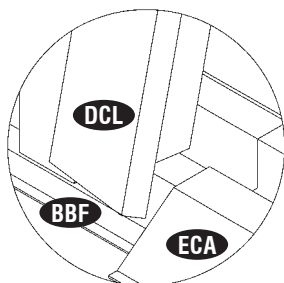

Fig.1

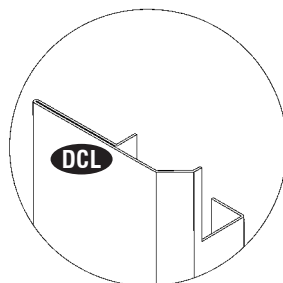
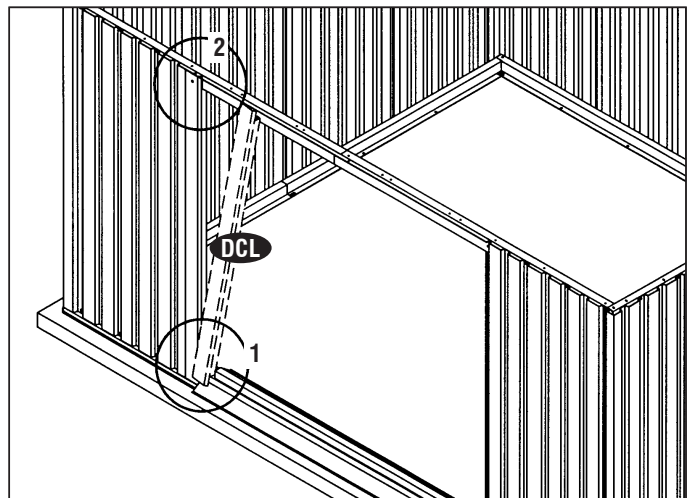
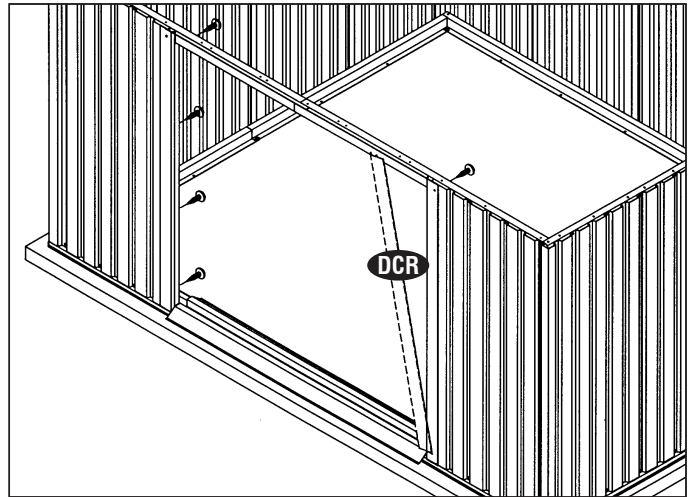
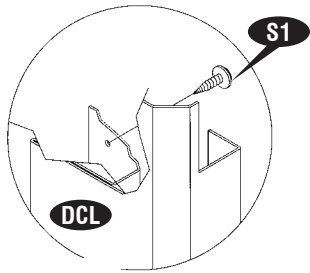

Fig.2



35. Secure the door column with (S1) screws.



36. Place the sliding channel cover (SCA) on top of the sliding support (SSRA) and secure with (S1)

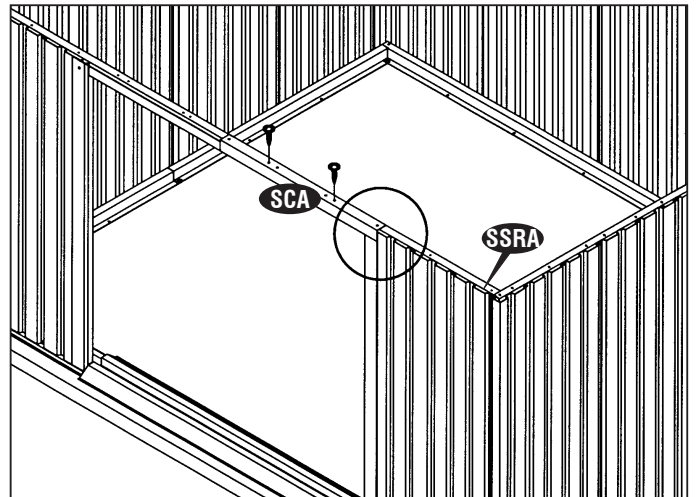
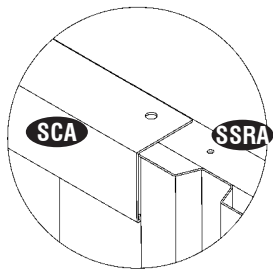

37. Place the sliding channel cover (SCA) on top of the sliding support (SSLA) and secure with (S1) screws.

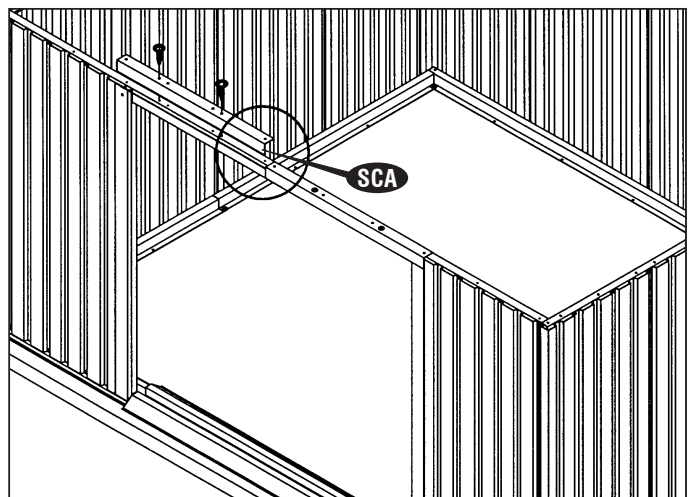
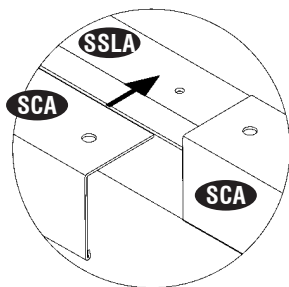

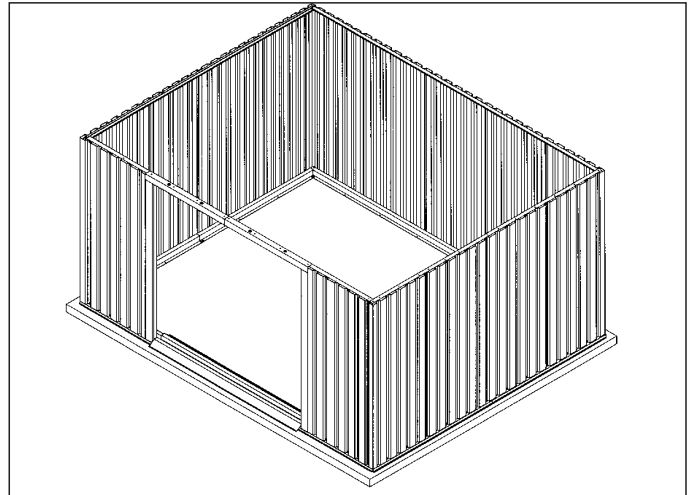

C. Roof

Note All parts are clearly marked and care should be taken to use the correct one.

Parts Needed:

(2) Gable panel left	☐	☐	☐	(GPLA)	(2) Roof flashing front right / back left	☐	(RF1A)
(2) Gable panel right	☐	☐	☐	(GPRA)	(2) Roof flashing front left / back right	☐	(RF2A)
(2) Roof support bracket front left / back right	☐	☐	☐	(SB1A)	(4) Roof flashing front/ back	☐	(RFSA)
(2) Roof support bracket front right / back left	☐	☐	☐	(SB2A)	(2) Roof flashing center	☐	(RFCA)
(4) Roof support	☐	☐	☐	(RS1A)	(2) Flashing end cap	☐	(FC)
(4) Roof support	☐	☐	☐	(RS2A)	(4) Ventilation cover	☐	(VC)
(2) Roof panel	☐	☐	☐	(RP1A)	(4) Top corners	☐	(TC)
(2) Roof panel	☐	☐	☐	(RP2A)	(3.1 MTR) WEATHER STRIPPING TAPE	☐	(WST)
(2) Roof panel	☐	☐	☐	(RP3A)	(128) Sheet metal screw	☐	(S1)
(2) Roof panel	☐	☐	☐	(RP4A)	(4) Sheet metal screw	☐	(S2)
					(56) Machine screw with nut	☐	(S3)
					(128) Plastic washer	☐	(PW)

1. Place the Gable panel (GPRA) on top of the sliding channel (SRA). See fig.1. Push the Gable panel inside the top angle side (AS2A). See fig.2. Align the

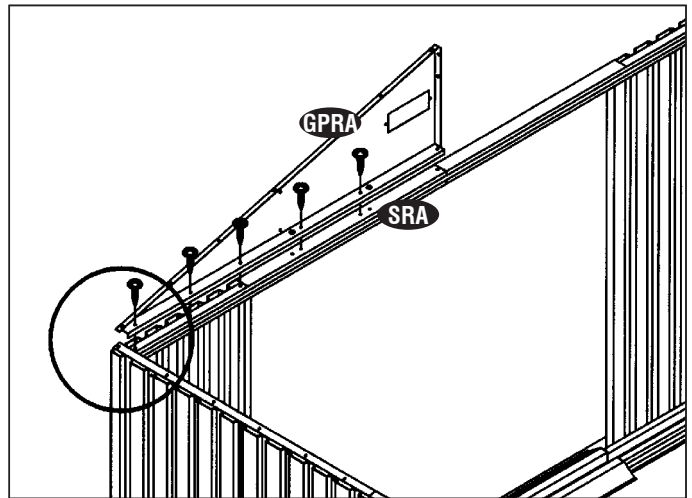
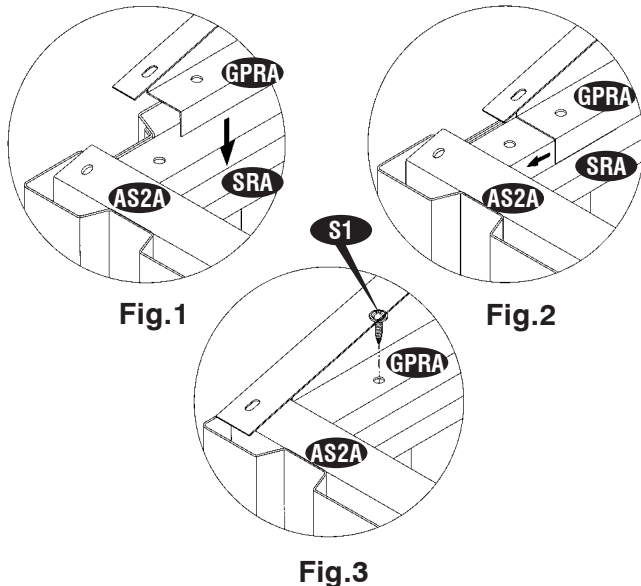

2. Place the Gable Panel (GPLA) on top of the sliding channel (SLA). Insert the Gable panel inside the Top

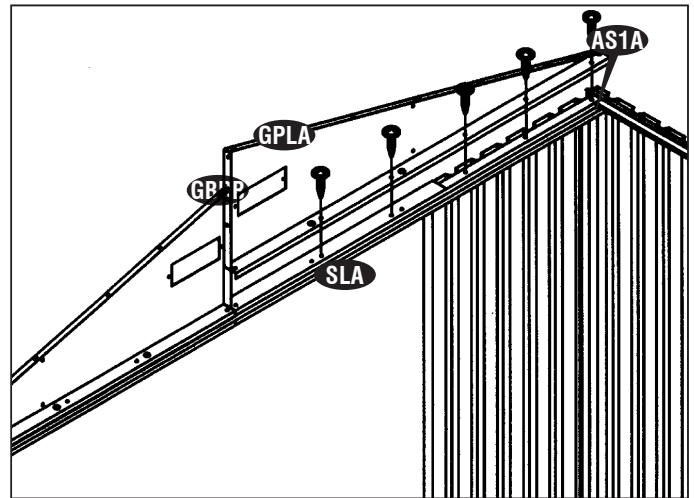

3. Assemble the Gable panel (GPLA) & (GPRA) together

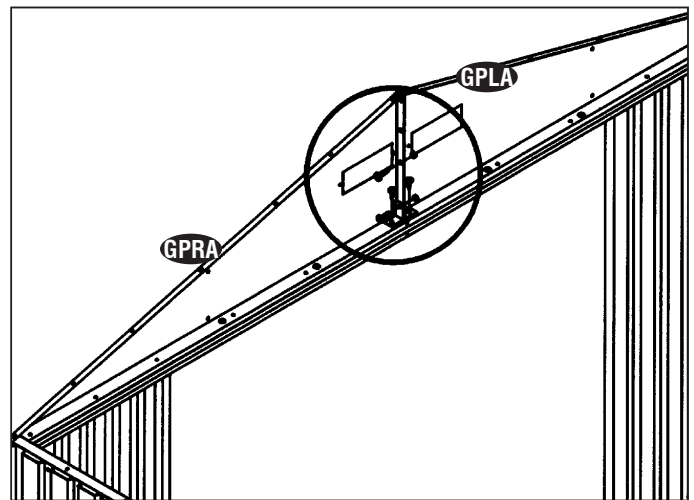
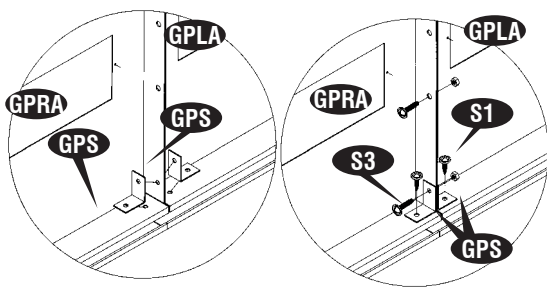

4. Place the Gable panel (GPRA) & (GPLA) on top of the Top angle (ABLA) & (ABRA). See fig. 1. Insert the Gable Panel into the Top angle (AS1A) & (AS2A). Align the holes with Top angle

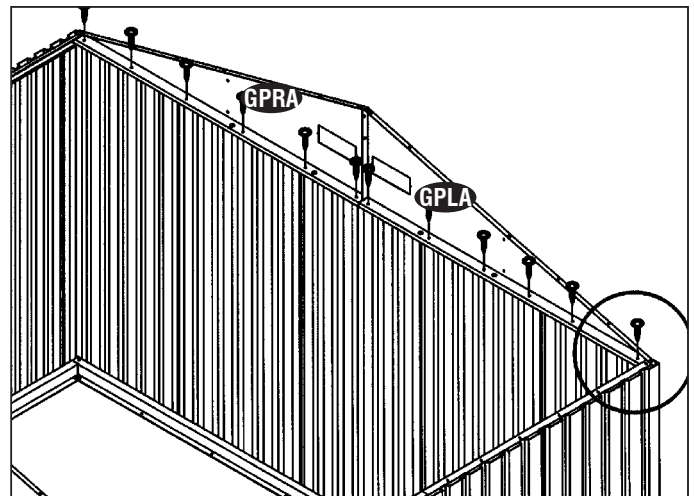
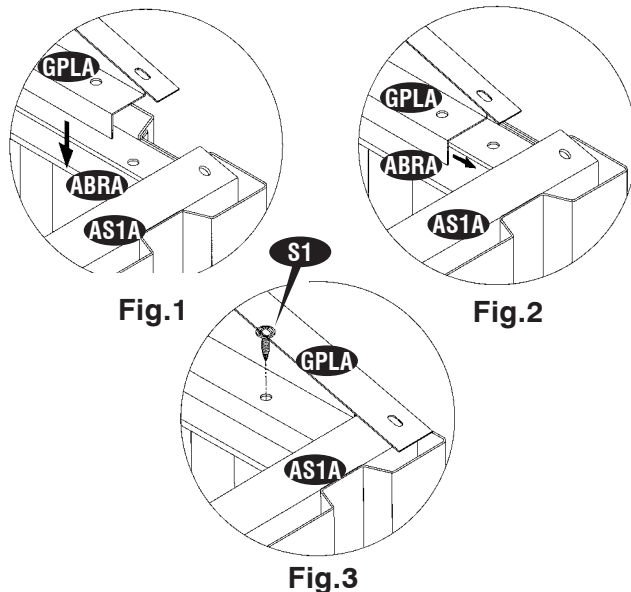

5. Assemble the Gable panel (GPLA) & (GPRA)

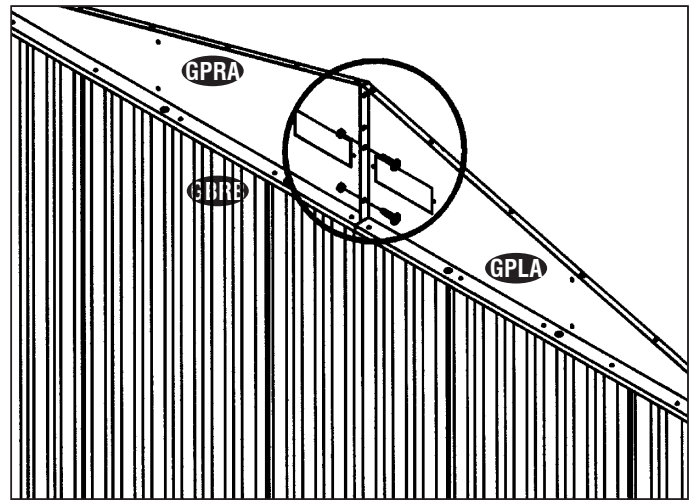
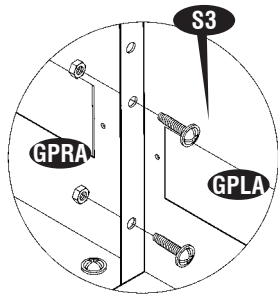

6. Assemble two roof structure (RS1A) & (RS2A) together with (S3) bolt and nut. Fix roof support brackets (SB1A) & (SB2A) on both ends with (S3)

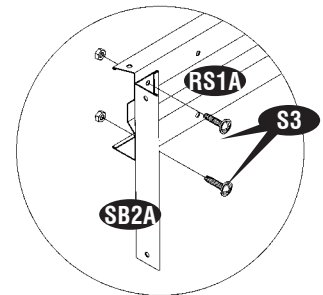
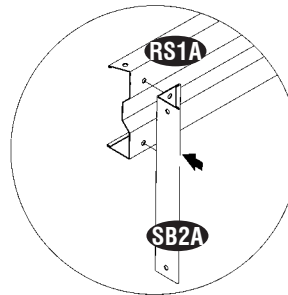
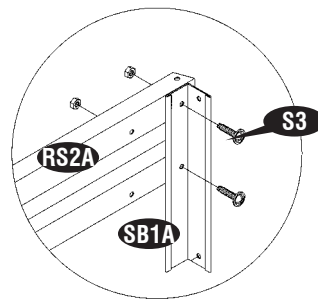
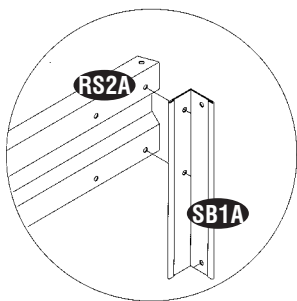
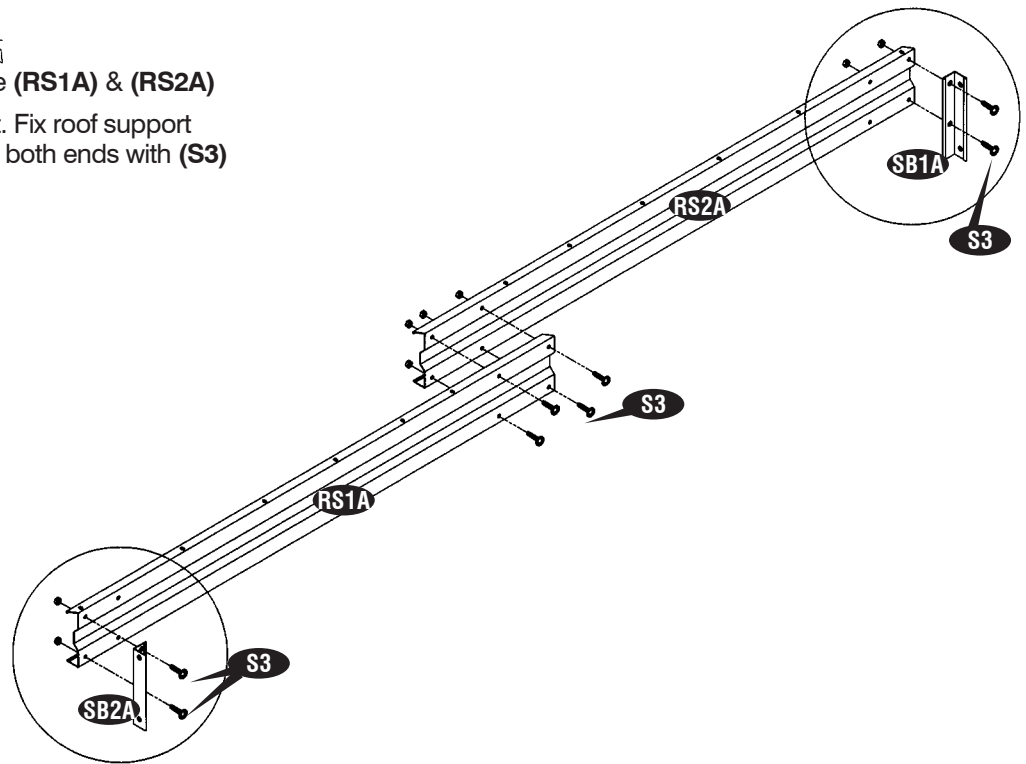

7. Assemble four roof structure together with (S3)

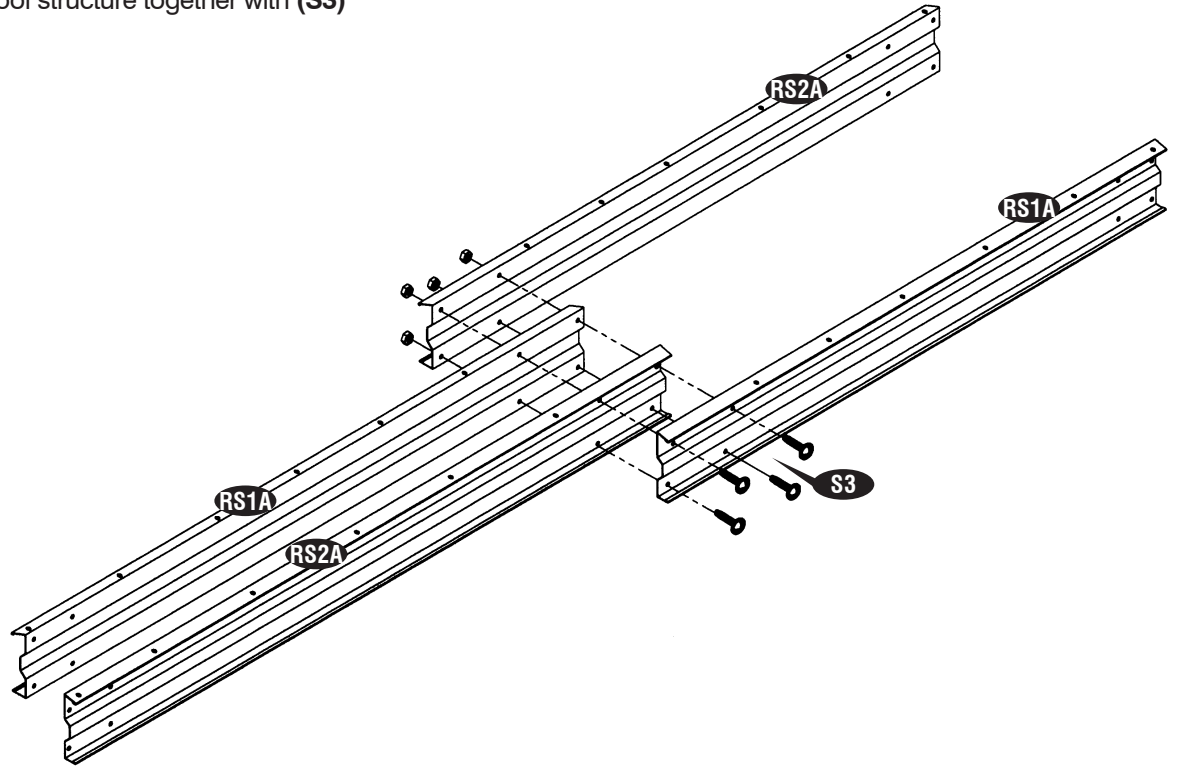

8. Fix the roof structure one end with roof support bracket to the gable panel using (S3) bolt and nut. See fig. Fix the other end also with the roof support bracket.

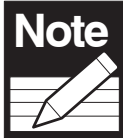

Note Make sure the taper side on roof structure must be up side.

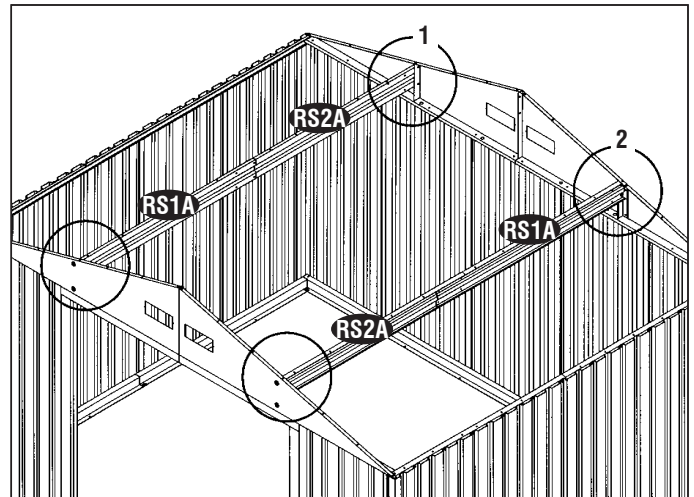

Taper side

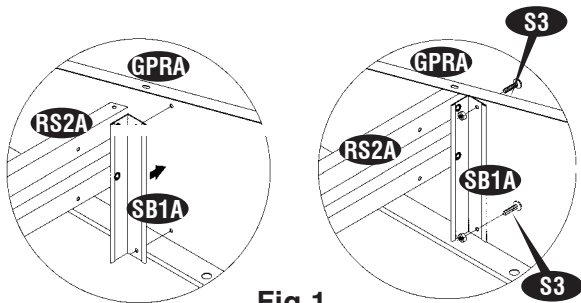

Fig.1

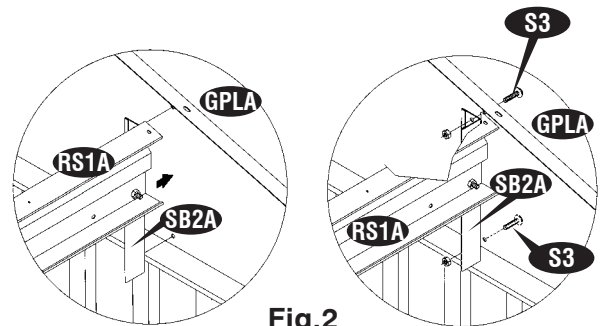
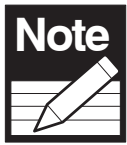
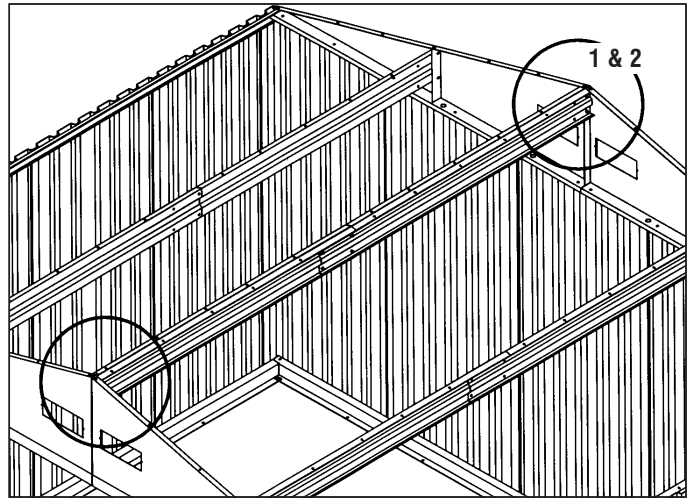
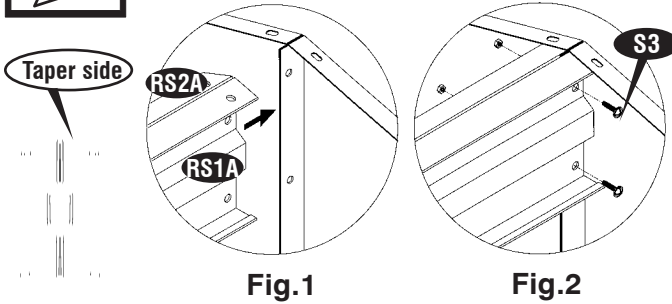

Fig.2

9. Insert the one end of the roof structure assembly to the Gable panel. The Gable panel should go in between roof structure assembly. Secure with (S3)



Note Make sure the taper side on roof structure must be up side.



10. Place the roof panel (RP4A) on top of the Gable panel (GPRA). Line up the holes with Gable panel and secure with (S3) bolt and nut with washers.

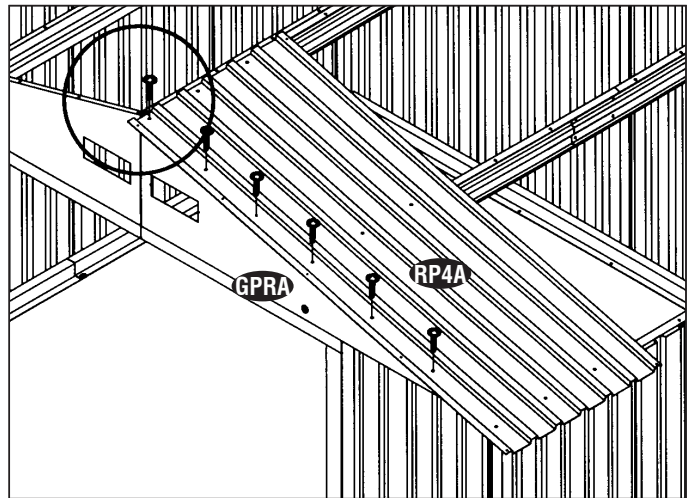
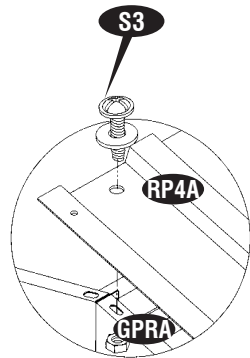

11. Line up the holes with roof structure and top angle side and secure with (S1) screws with

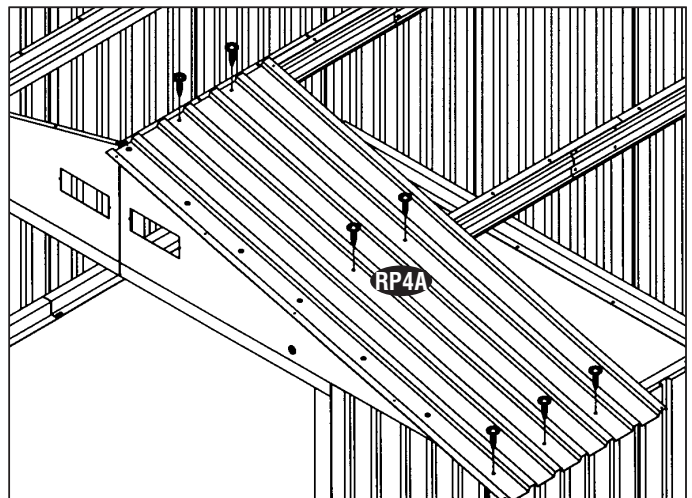

12. Place the roof panel (RP3A) on the roof

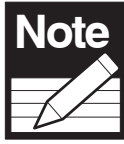

Note Make sure the overlapping position for roof panel is as shown in blowup.

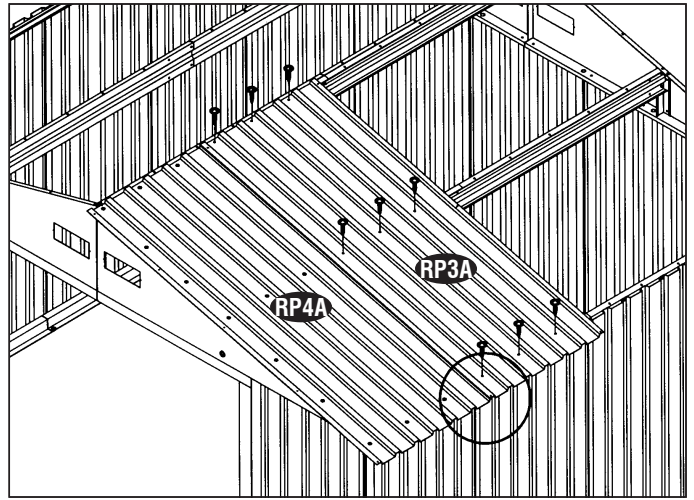
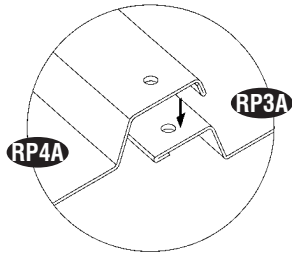

13. Place the roof panel (RP2A) on the roof

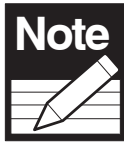

Note Make sure the overlapping position for roof panel is as shown in blowup.

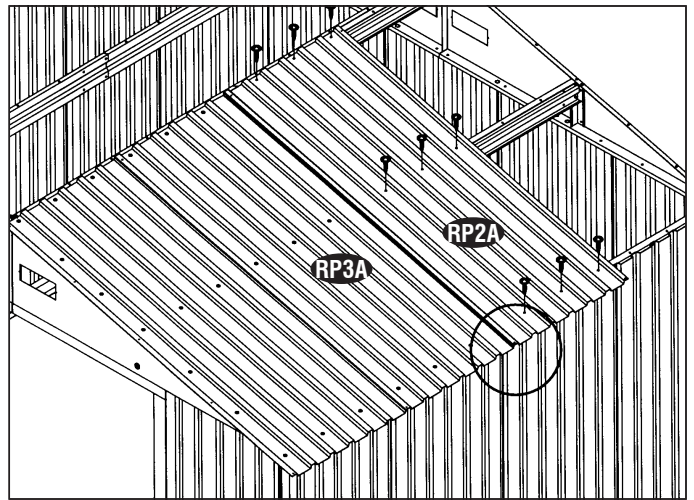
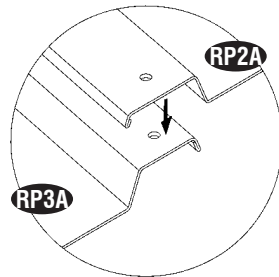

14. Place the roof panel (RP1A) on the roof structure and Gable panel. Secure with (S1) screws with

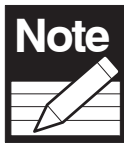

Note Make sure the overlapping position for roof panel is as shown in blowup.

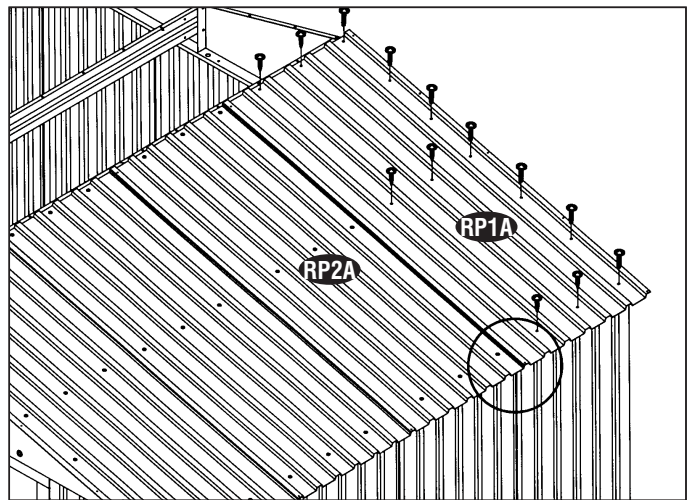
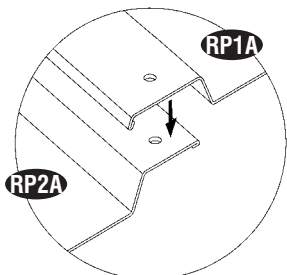

15. Place the roof panel (RP4A) on top of Gable panel and roof structure. Use (S3) bolt and nut with washers for Gable panel and use (S1) screws with

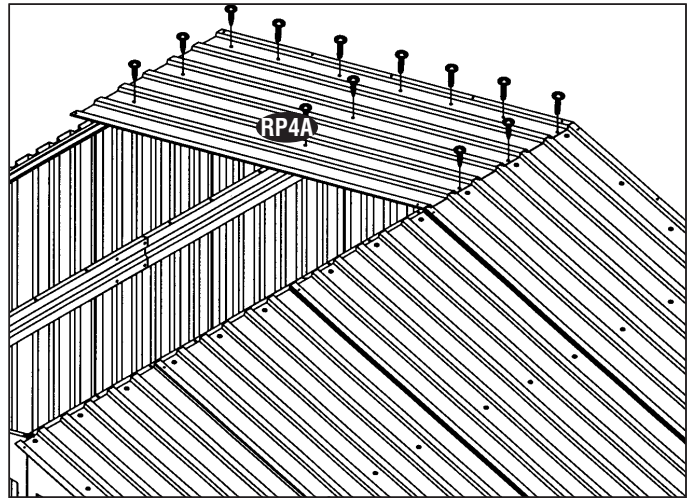

16. Place the roof panel (RP3A) on the roof

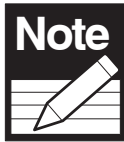

Note Make sure the overlapping position for roof panel is as shown in blowup.

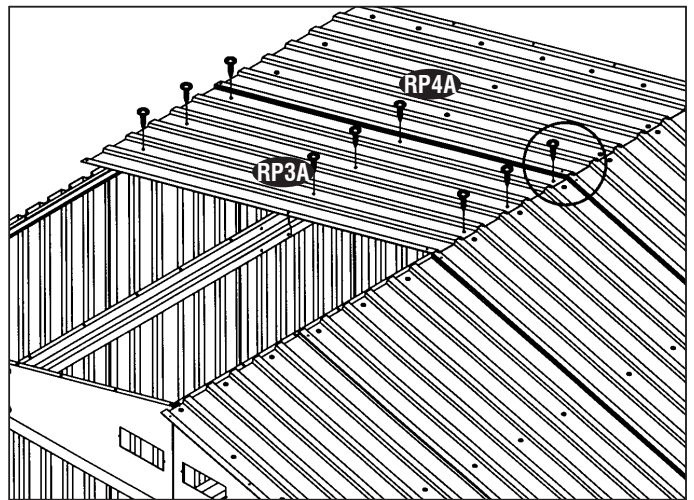
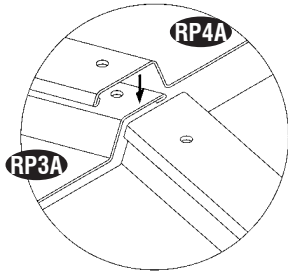

17. Place the roof panel (RP2A) on the roof

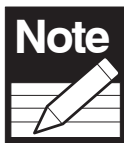

Note Make sure the overlapping position for roof panel is as shown in blowup.

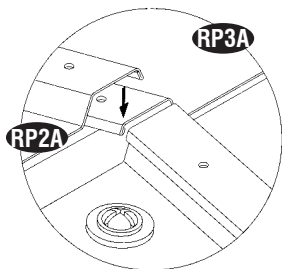

18. Place the roof panel (**RP1A**) and secure with (**S3**) bolt and nut with washers to Gable panel and

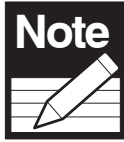

Make sure the overlapping position for roof panel is as shown in blowup.

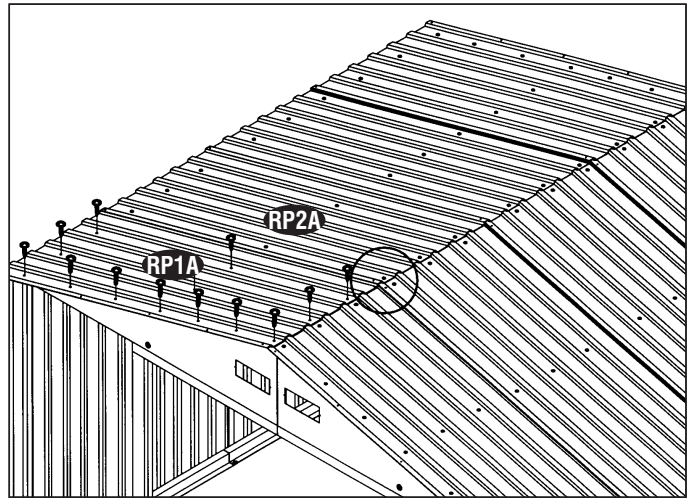
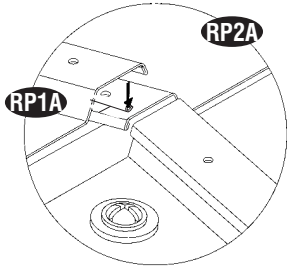

19. Put weather stripping tape (**WST**) before fixing

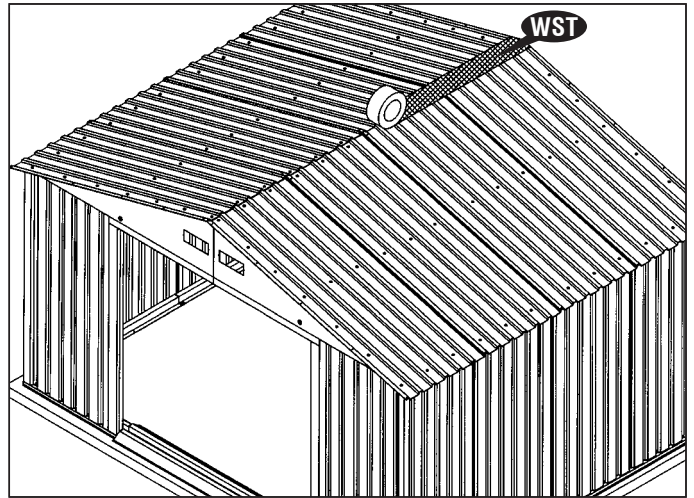

20. Assemble the roof flashing (**RF1A**) and (**RF2A**) with roof panel as shown in fig. Use (**S1**) screws with washers to secure.

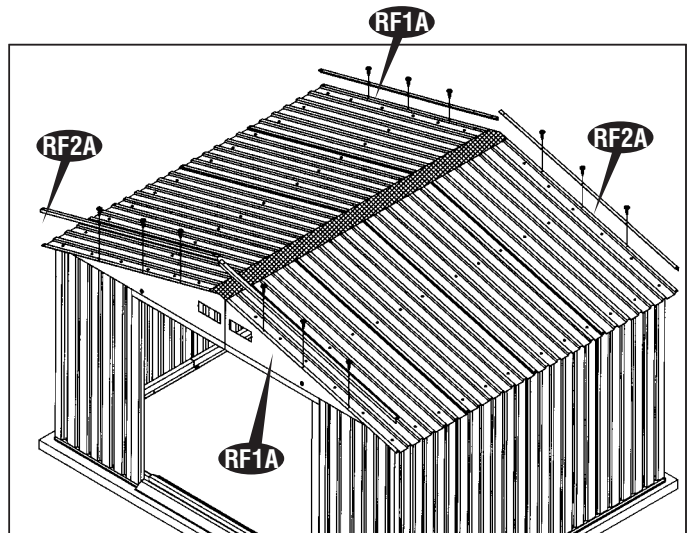

21. Assemble the roof flashing (RFSA) with roof

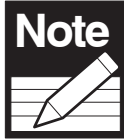

Note Make sure the overlapping position for roof flashing is as shown in blowup.

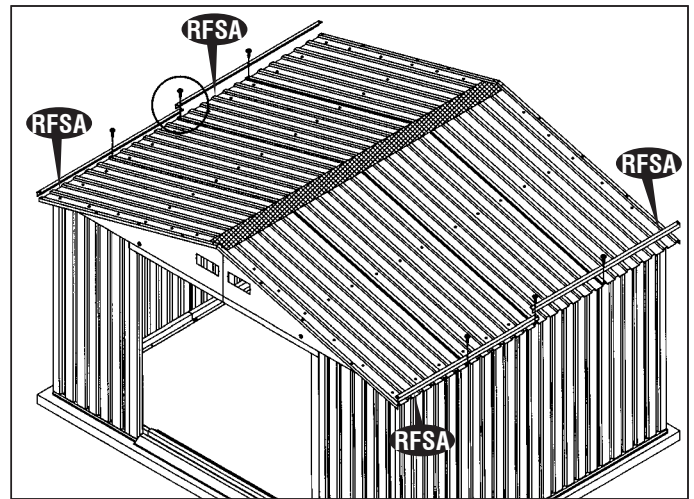
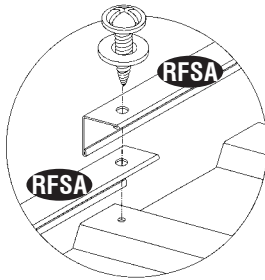

22. Assemble together the roof flashing center

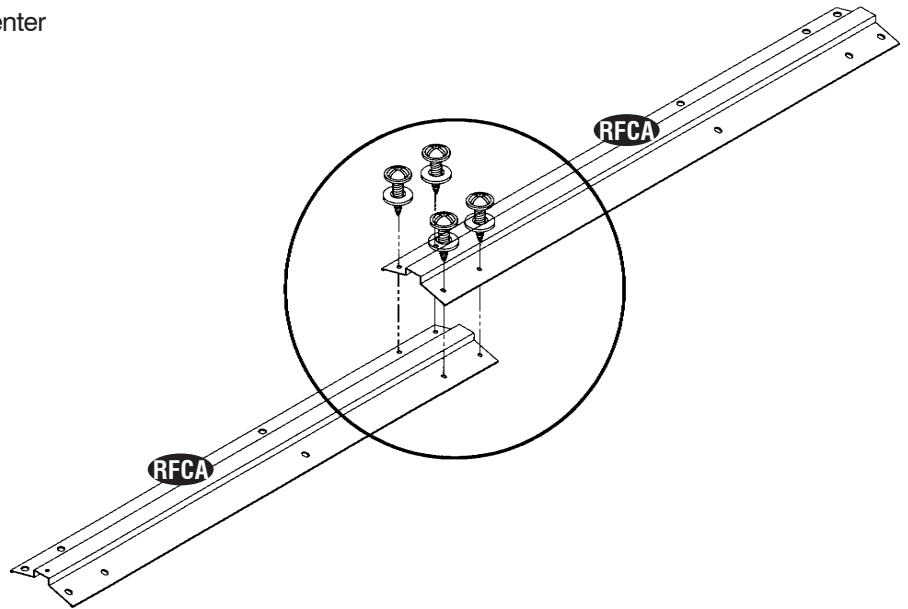
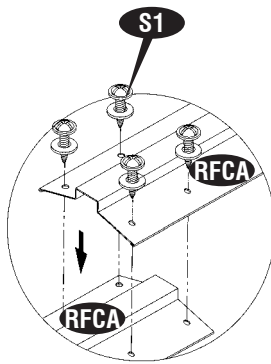

23. Place the assembled the roof flashing center on top of the roof panel. Line up the holes and secure with (S1) screws with washers.

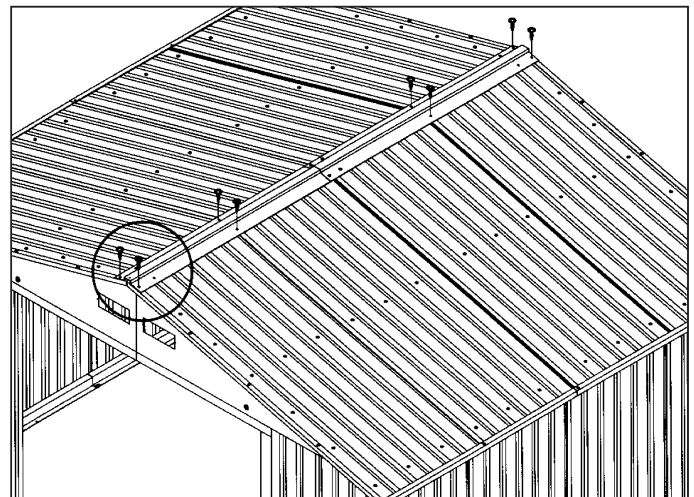
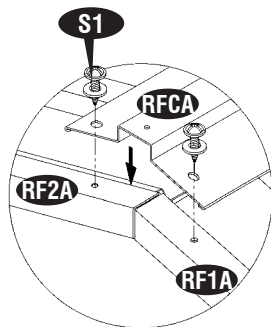

24. Slide the flashing end cap to the front and back top of the roof and secure with (S1) screws with washers.

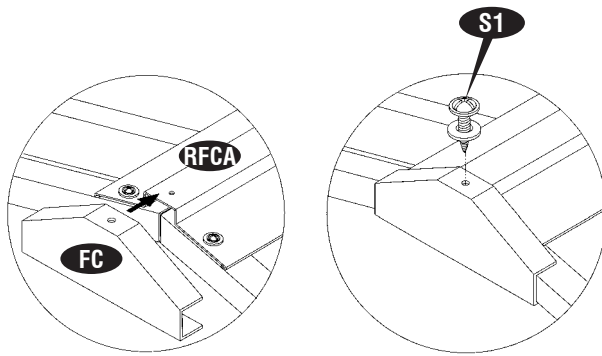
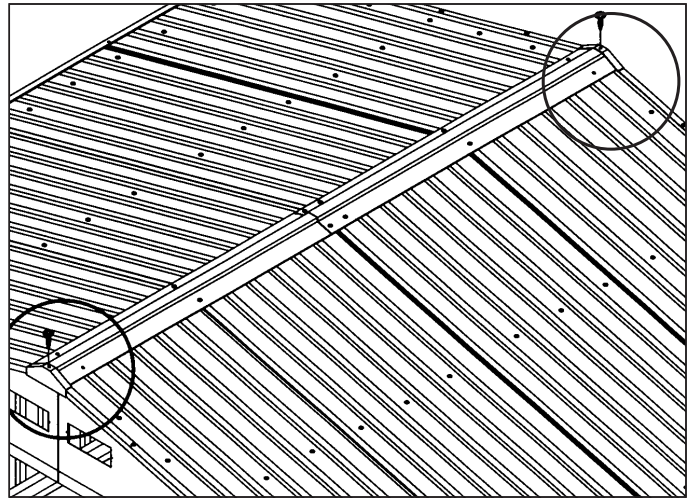
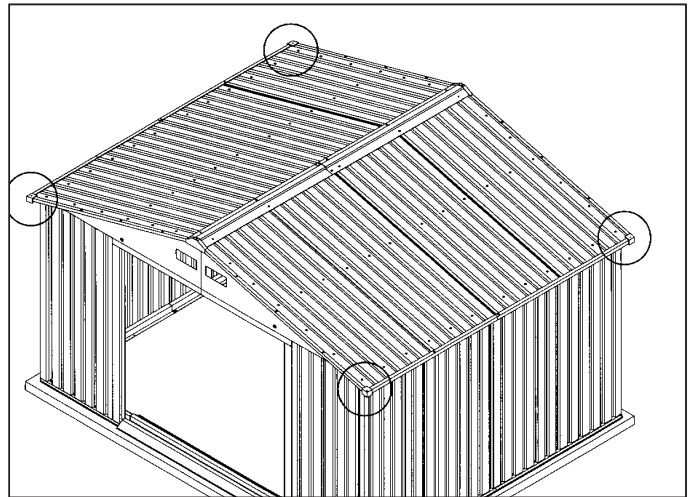
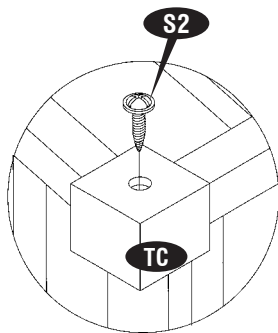

Fig.1

Fig.2



25. Place the top corner (TC) on the roof flashing



26. Insert the ventilation cover (VC) into the front

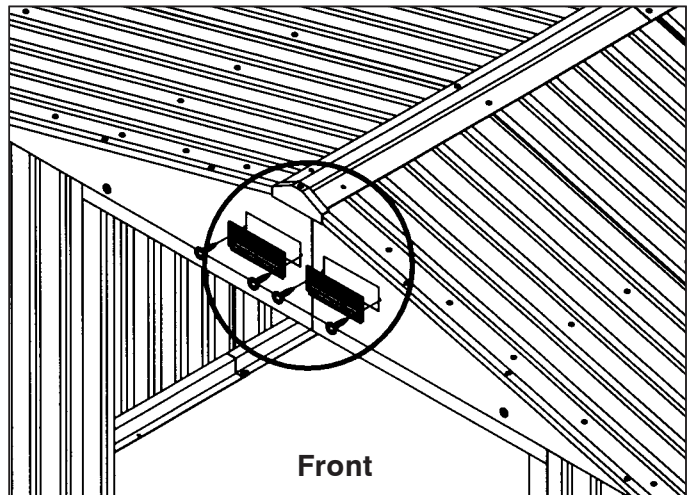
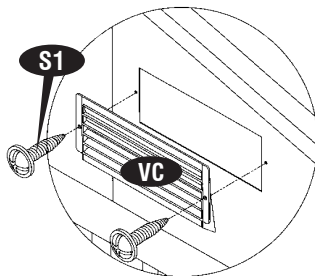

27. Insert the ventilation cover (VC) into the back Gable panel and secure with (S1) screws.

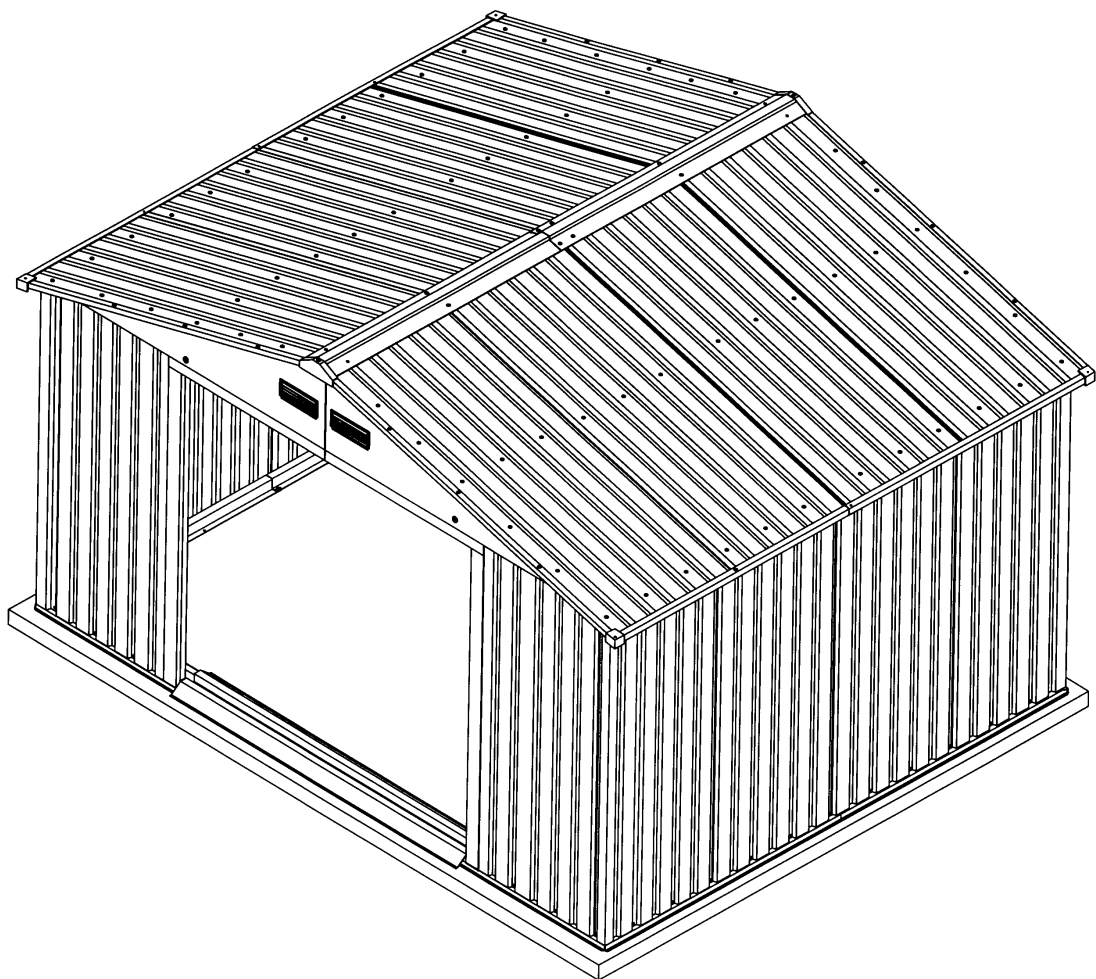
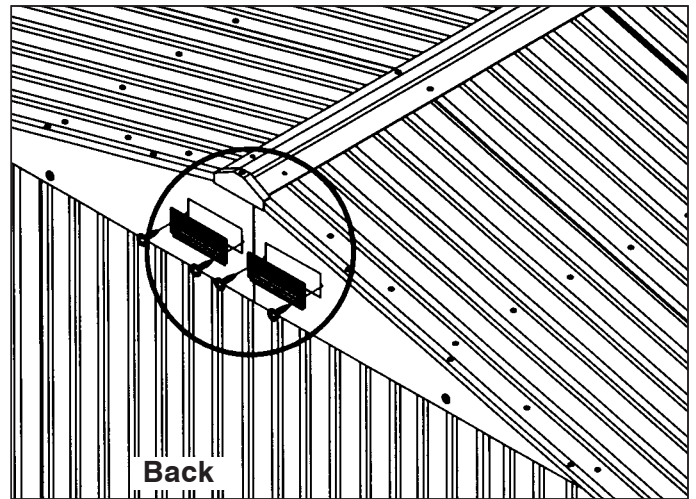
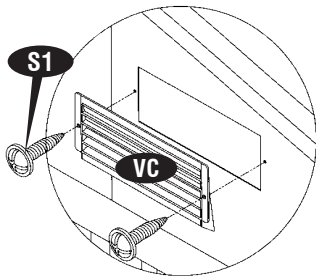

D. Door

Parts Needed:

- | | | |
|---|---|---------|
| (1) Door panel left | □ | (DPL1A) |
| (1) Door panel left | □ | (DPL2A) |
| (1) Door panel right | □ | (DPR1A) |
| (1) Door panel left | □ | (DPR2A) |
| (2) Door panel strips side left and right | □ | (DSS) |
| (1) Door panel strip top left | □ | (TSLA) |
| (1) Door panel strip top right | □ | (TSRA) |
| (1) Door panel strip bottom left | □ | (BSLA) |
| (1) Door panel strip bottom right | □ | (BSRA) |
| (2) Door handle | □ | (DH) |
| (4) Bottom Slider | □ | (BS) |
| (16) Sheet metal screw | □ | (S1) |
| (30) Machine screw | □ | (S3) |
| (18) Plastic washer | □ | (PW) |

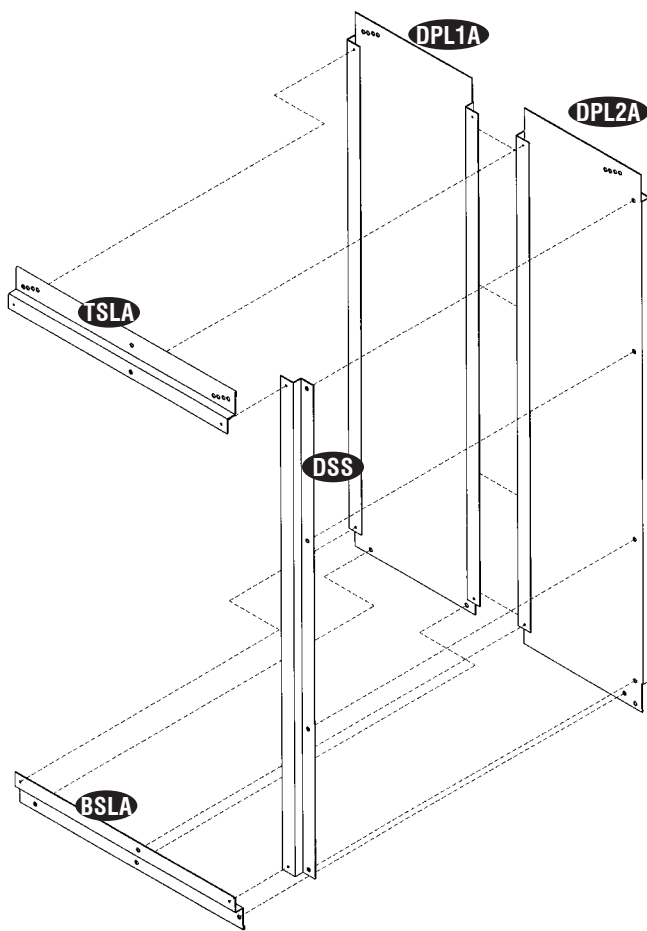

Left Door

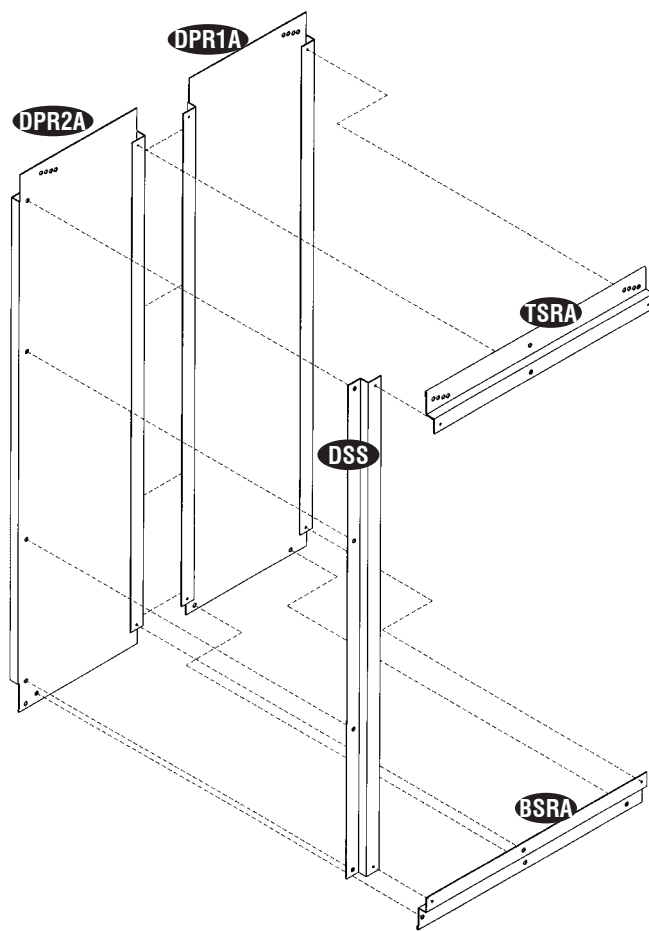

Right Door

Right Door Assembly

1. Assemble the door panel (DPR1A) & (DPR2A) together with (S3) bolt and nut from inside.

Note Remove the Polyethylene Film

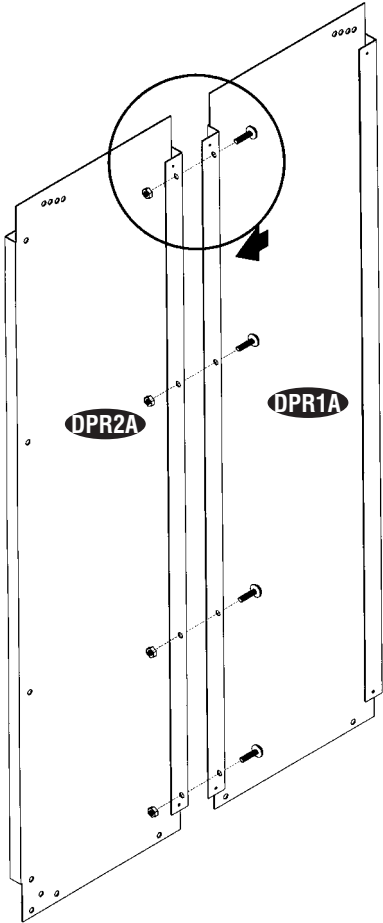
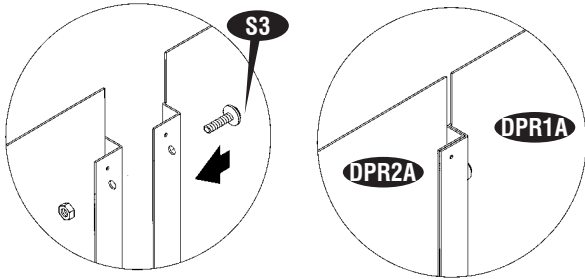

2. Assemble the door panel strip side (DSS) to the door panel (DPR2A) from inside. Use (S3) bolt and

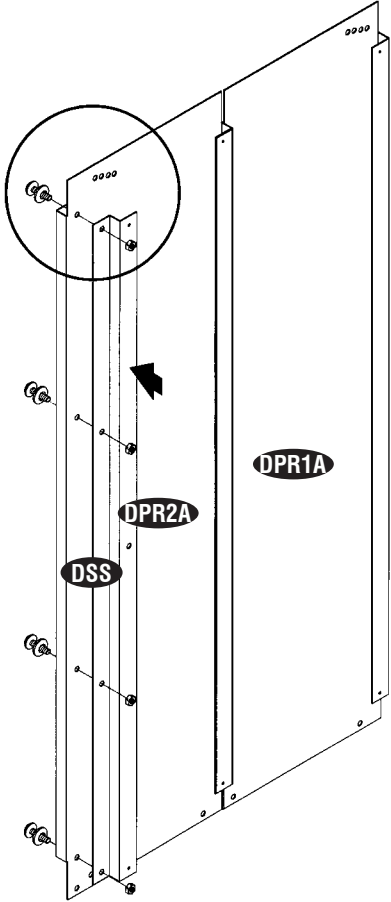
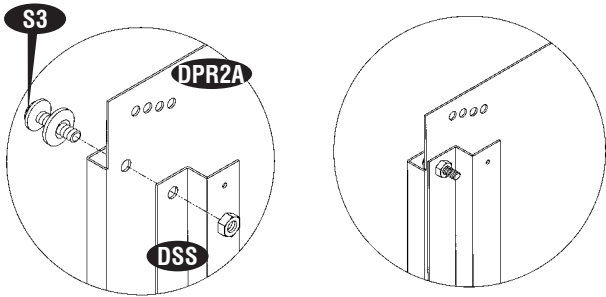

3. Assemble the door panel strip (**TSRA**) with door panel. Make sure the door panel top edge to be inserted into the (**TSRA**). See fig.1. Secure the (**TSRA**) with (**DSS**) and door panel with (**S1**) screws. See fig. 2. Use (**S3**) bolt and nut with washers to secure with

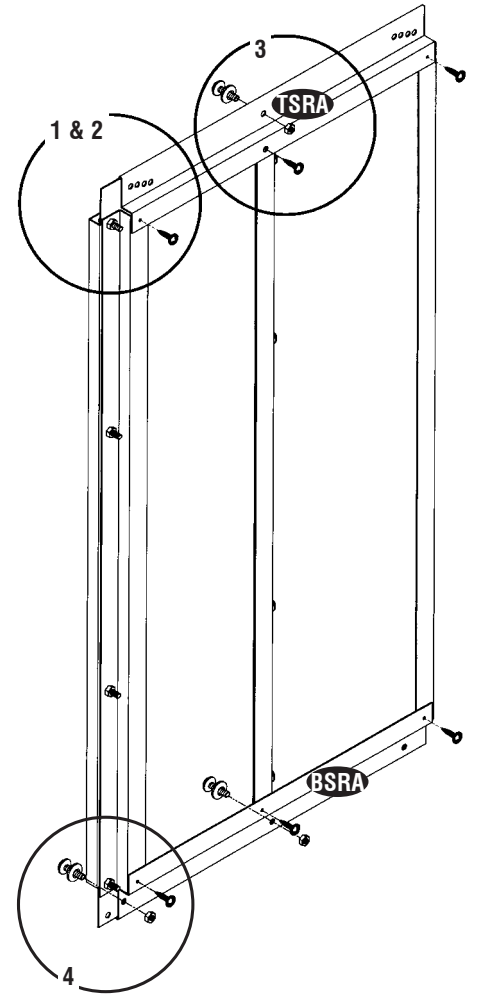
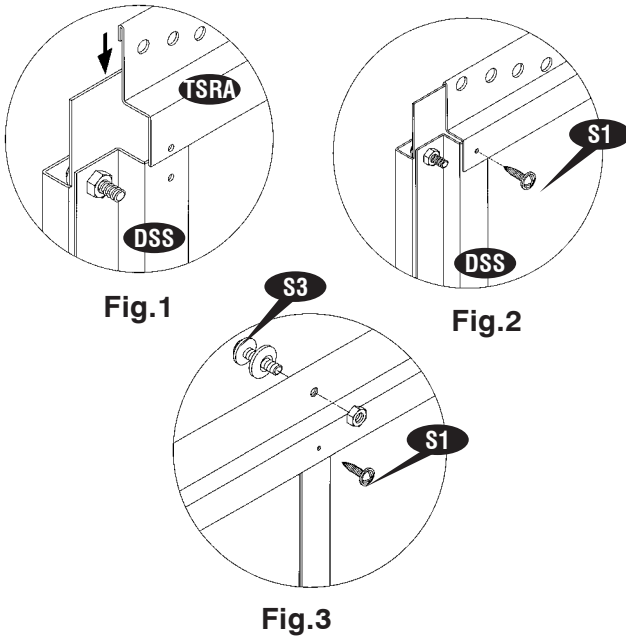

3a. Assemble the door panel strip (**BSRA**) with door panel. Make sure the bottom edge of the door panel to be inserted into the (**BSRA**). Secure with (**S1**) screws to the (**DSS**) and use (**S3**) bolt and nut with washers with door panel. See fig. 4.

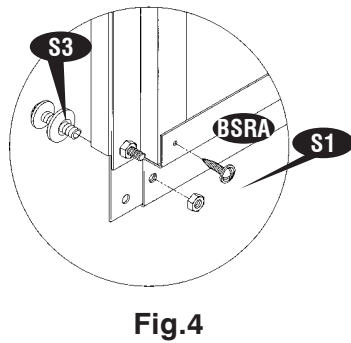

4. Assemble the bottom slider (**BS**) to the door panel bottom side at both edge with (**S3**) bolt and nut with washers.

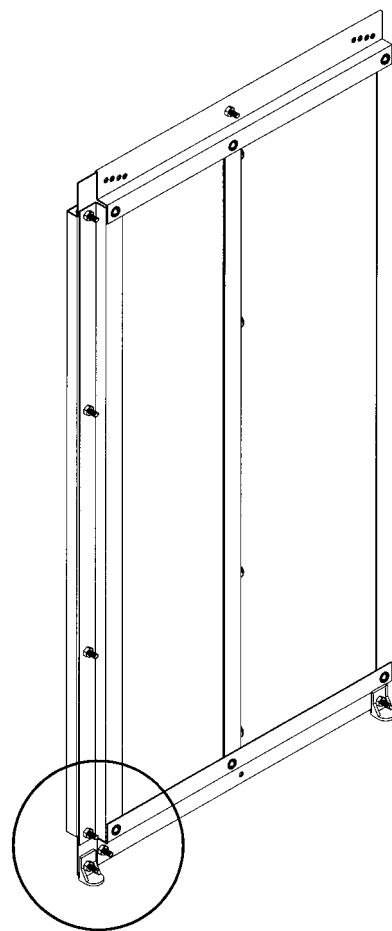
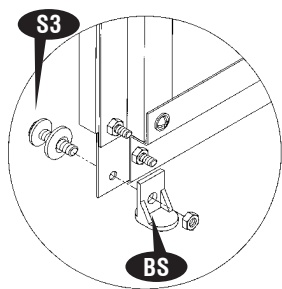

5. Fix the door handle (**DH**) with door panel from

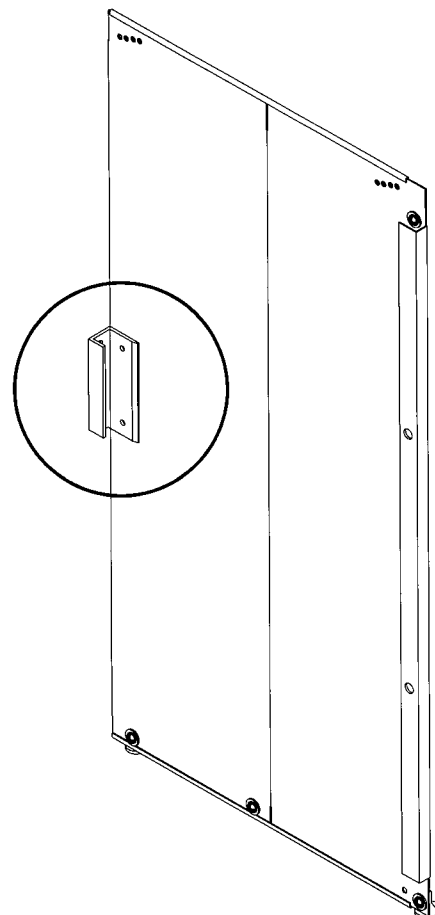
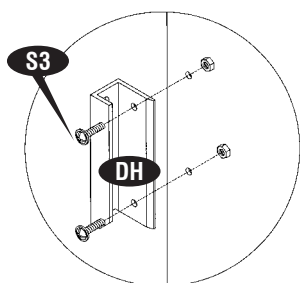

Left Door Assembly

6. Assemble the door panel (DPL1A) & (DPL2A) together with (S3) bolt and nut from inside.

Note Remove the Polyethylene Film

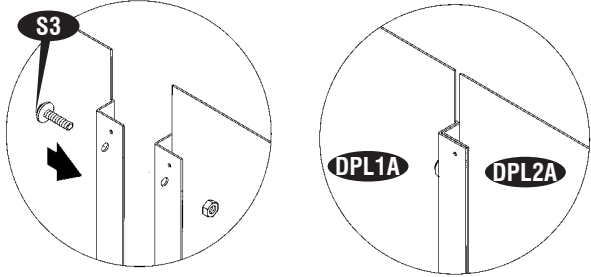

7. Assemble the door panel strip side (DSS) to the door panel (DPL2A) from inside. Use (S3) bolt and nut

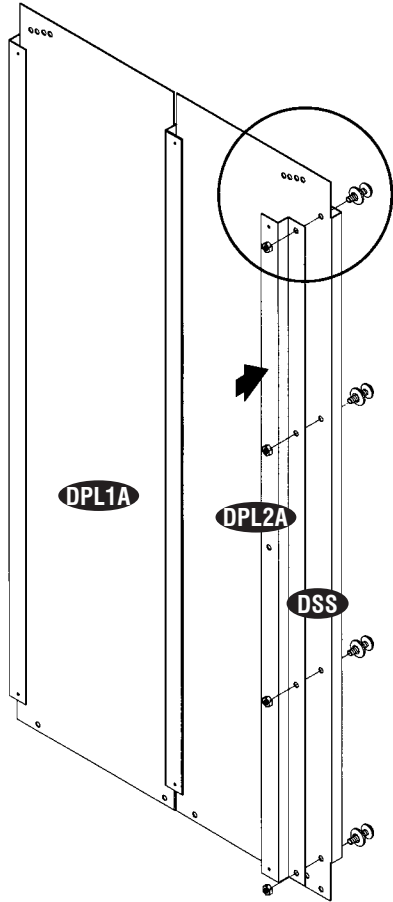
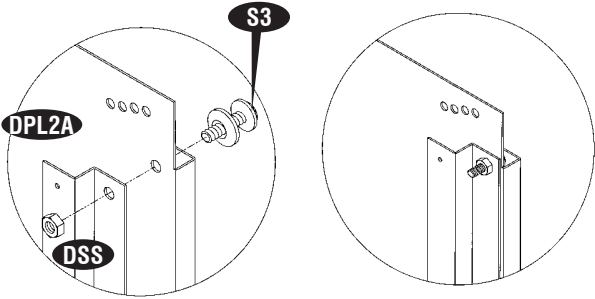

8. Assemble the door panel strip (**TSLA**) with door panel. Make sure the door panel top edge to be inserted into the (**TSLA**). See fig. 1. Secure the (**TSLA**) with (**DSS**) and door panel with (**S1**) screws. See fig. 2. Use (**S3**) bolt and nut with washers to secure with door panel at the middle of (**TSLA**). See fig. 3.

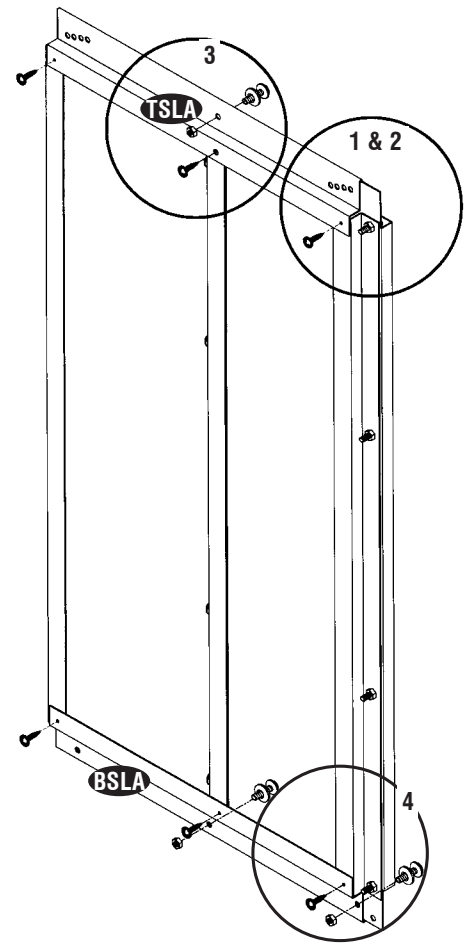
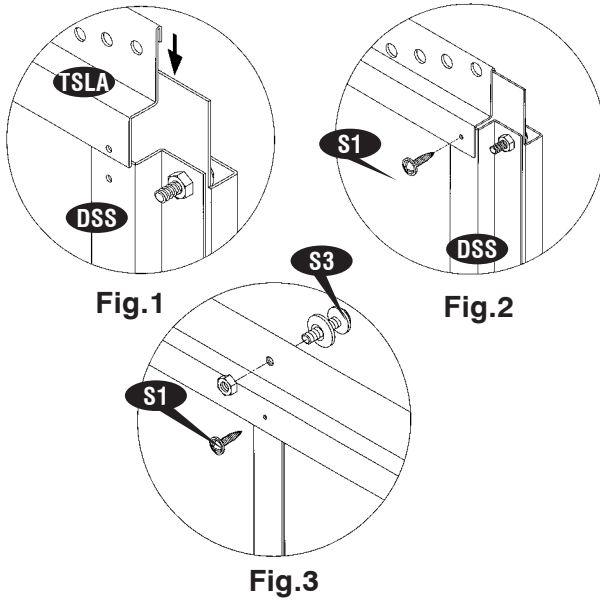

8a. Assemble the door panel strip (**BSLA**) with door panel. Make sure the bottom edge of the door panel to be inserted into the (**BSLA**). Secure with (**S1**) screws to the (**DSS**) and use (**S3**) bolt and nut with washers with door panel. See fig. 4.

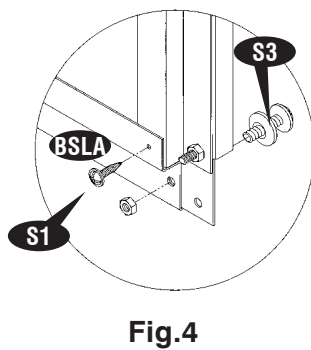

9. Assemble the bottom slider (**BS**) to the door panel bottom side at both edge with (**S3**) bolt and nut with washers.

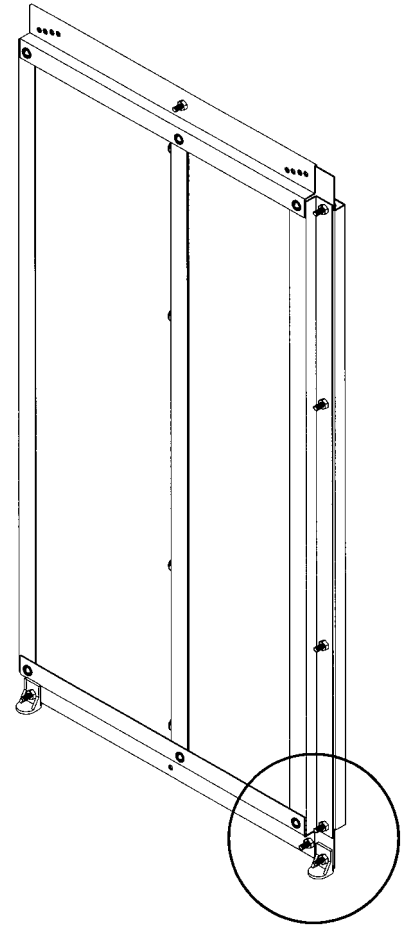
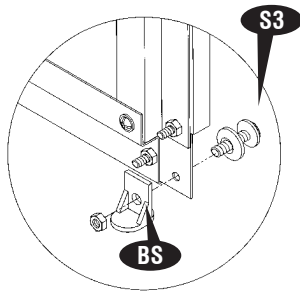

10. Fix the door handle (**DH**) with door panel from front side with bolt and nut.

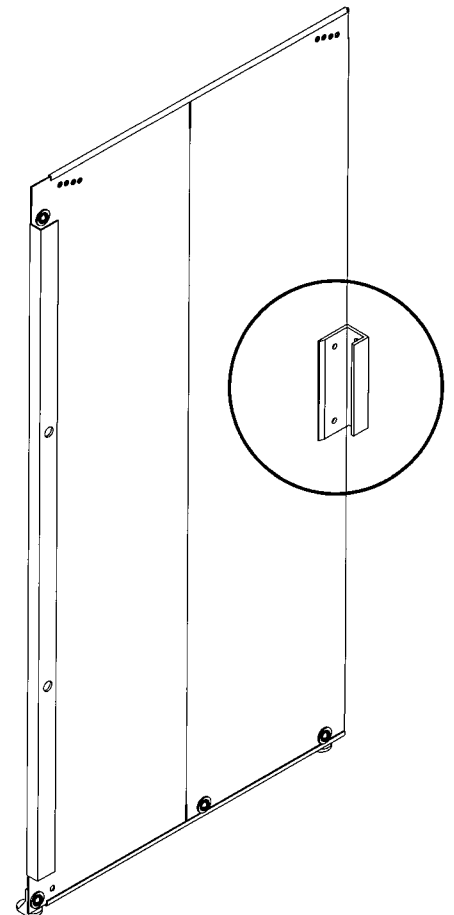
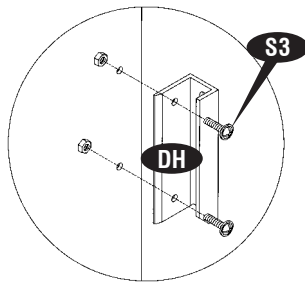

11. Slide the door panel assembly into the base bar front (**BBF**). Make sure the bottom slider (**BS**) should slide inside the base bar front. See fig.1. Fix the door panel top to the top slider (**TS**) with (**S1**) screws. See fig.2 & 3

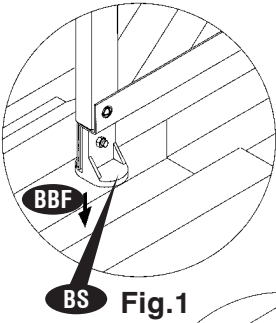

Fig.1

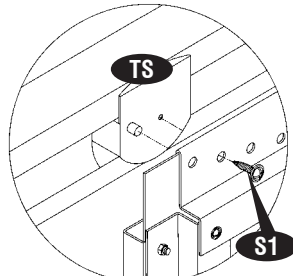

Fig.2

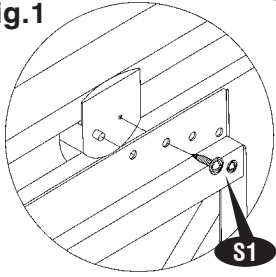

Fig.3

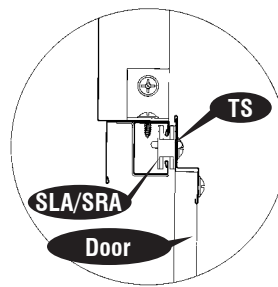
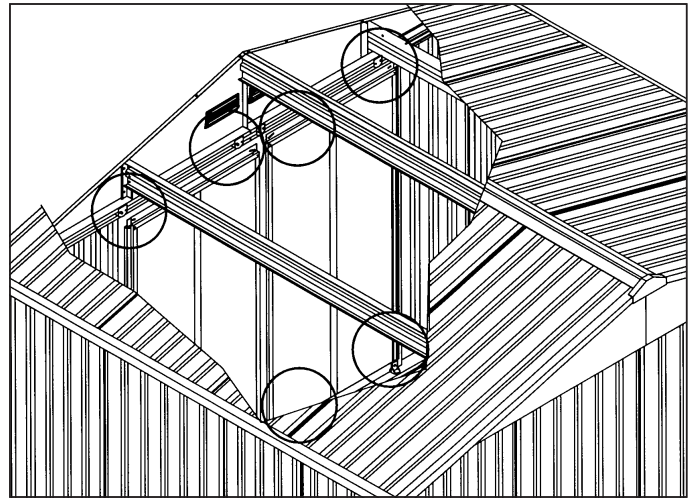

Fig.4

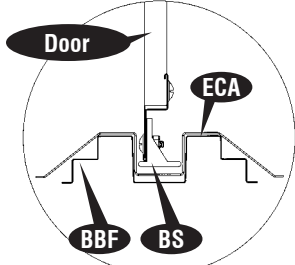
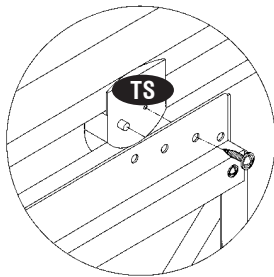

Fig.5

11a. To get proper alignment of the door realign the holes with door panel. See fig.



IMPORTANT

12. Fix the plastic screw cover (**PC**) to the screws and bolts edge from inside to prevent injury.

